

**KENT
USA**

CNC HORIZONTAL BORING
& MILLING MACHINE



Conventional Horizontal Boring & Milling Machine
KBM Series



CNC Horizontal Machining Center
KHM Series



CNC Double Column Machining Center
KDM Series



CNC Horizontal Heavy Duty Milling Machine
KMM Series



KBM-W
series

**KENT
USA**

Kent Industrial USA, Inc.

1231 Edinger Avenue
Tustin, CA 92780 USA

+1.714.258.8526
sales@kentusa.com
www.kentusa.com

**CNC Horizontal Boring
& Milling Machine**

www.kentusa.com

KBM-11020IS, 11020RS, 11020RSA SERIES

KBM-13020IS, 13020RS SERIES

FIXED COLUMN

CNC HORIZONTAL BORING & MILLING MACHINE

- Fixed column construction.
- Suitable for heavy boring and milling for workpiece weight under 5 tons.
- Minimum deflection of spindle extension (W- axis).
- 360D 1° indexing CNC rotary table. (KBM-11020IS, KBM-13020IS)
- 0.001° CNC rotary table. (KBM-11020RSA, KBM-11020RS, KBM-13020RS)
- 40-tool magazine is standard.
- 60-tool magazine is optional.



Perfectly Designed To Optimize Rigidity And Stability

Rigid & Stable Structure

All structural parts are manufactured from high quality cast iron (FC 30), tempered and stress relieved.

Guide Ways

Box ways on X and Y-axis.
Four linear guide ways on Z-axis.

Large Ball Screws

X, Y, Z-axis are transmitted through Ø63 mm, class C3 ball screws, featuring maximum rigidity.

Finite Element Analysis (FEA)

The major structural parts are designed with Finite Element Analysis software to simulate stress/strain condition.

Linear Scales on Three Axes

X, Y, Z-axis are all equipped with linear scales to ensure high positioning accuracy.

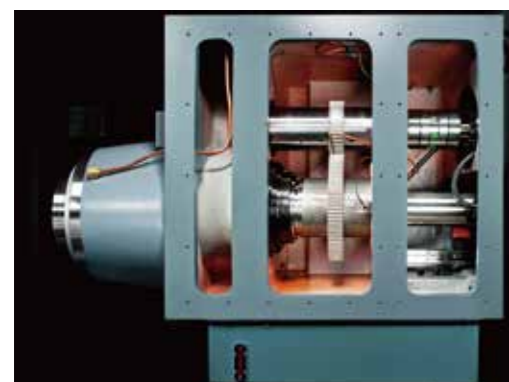
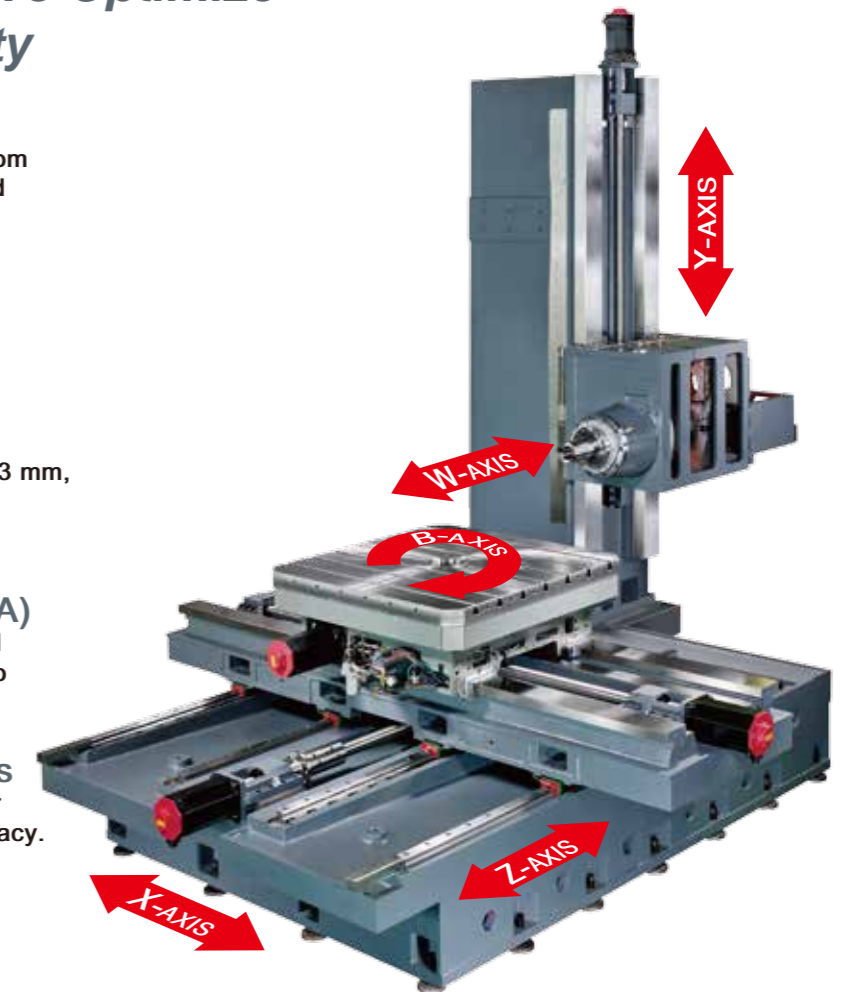

Rigid, Powerful Spindle Head

- The spindle head is reinforced with cage-shape ribs for increased rigidity.
- The spindle head integrates a self-made gearbox in combination with a German gearbox with 1: 8 teeth ratio, providing greater torque output in heavy cutting. (1:11 low speed teeth ratio is available)



KBM-13020IS

Large external splash guard (Optional)

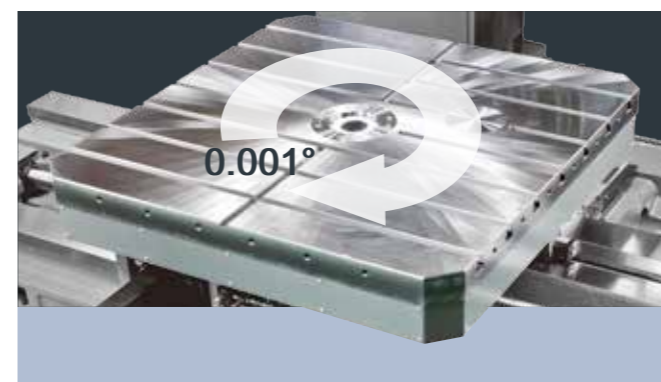

0.001° Direct-Drive Rotary Table

- 0.001° indexing rotary table. (Simultaneously controlled type is optional)
- 5 tons loading capacity.
- Automatic hydraulic clamping.
- Each 90° positioning with dowel pin.

NOTE: UBM-11020IS is equipped with a 360D teeth positioning table.

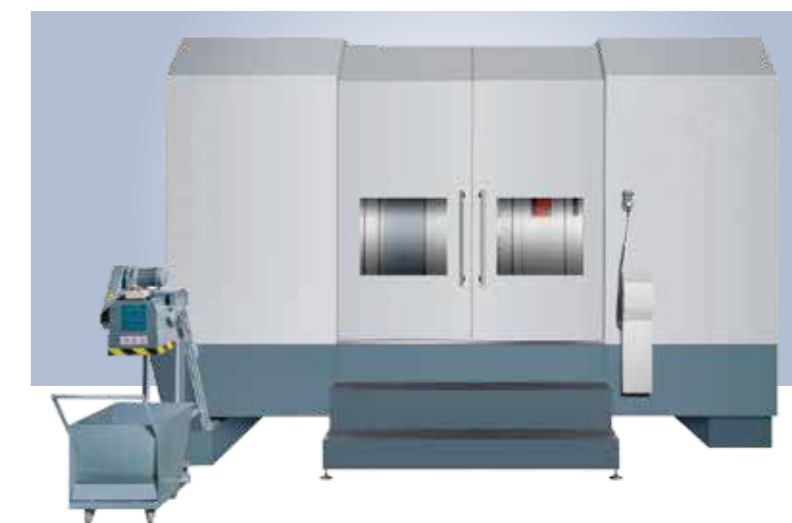

Fully enclosed splash guard (optional)

KBM-11020RSA, 11020ISA

FIXED COLUMN APC

CNC HORIZONTAL
BORING & MILLING MACHINE

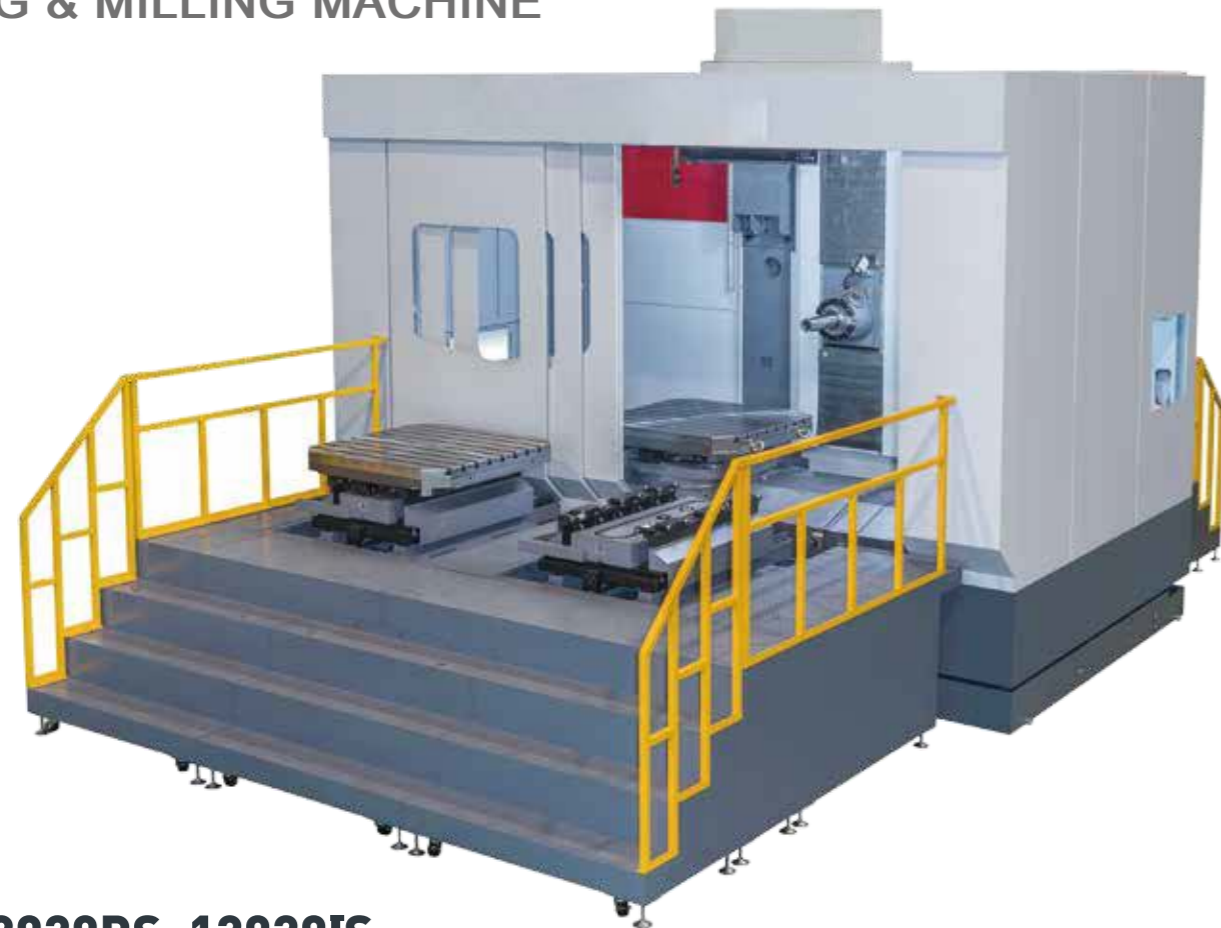

KBM-13020RS, 13020IS

- Spindle diameter Ø130mm.
- Fixed column construction.



- ※ W-axis 700mm
- ※ Large external splash guard (optional)

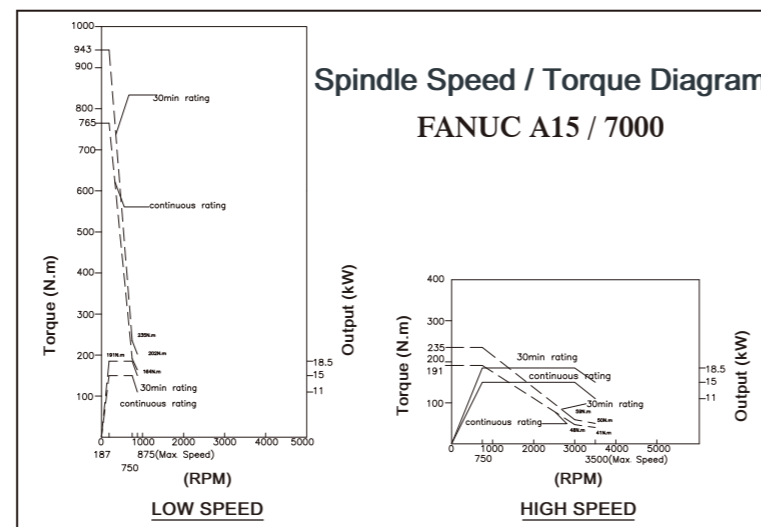

KBM-W series

MACHINE SPECIFICATIONS () : As Optional

MODEL	UNIT	KBM-11020IS	KBM-11020RS	KBM-11020ISA	KBM-11020RSA	KBM-13020IS	KBM-13020R	
TABLE	Table Size	mm	1250x1250x360D	1250x1250x0.001°	1250x1250x360D(Two-station)	1250x1250x0.001°(Two-station)	1250x1250x0.001°	
	T-slots Size	mm	22 x 7				22 x 7	
	Maximum Load	kg	5000				5000	
TRAVEL	X-Axis	mm	2000				2000	
	Y-Axis	mm	1800				1650 (2150)	
	Z-Axis	mm	1400				1400	
	W-Axis	mm	400 (500)				700	
SPINDLE	Diameter	mm	Ø110				Ø130	
	Speed	rpm	10 ~ 2500 (3000, 4000)				10 ~ 2000 (2500, 3000)	
DISTANCES	Taper		7/24 taper ISO.50, BT-50				7/24 taper ISO.50, BT-50	
	Spindle Center to Table	mm	0~1800				0~1600 (2150)	
	Spindle Nose to Table Center	mm	90~1890 (-10~1890)				-210~1890	
	Height From Ground to Table Surface	mm	1350				1350	
	Rapid Feed Rate X/Y/Z	m/min	12				12 / 10 / 12	
FEED RATE	Rapid Feed Rate W	m/min	10				6	
	Minimum Setting	mm/min	0.001				0.001	
	Cutting Feed Rate	mm/min	1~5000				1~5000	
	Spindle Servo Motor-cont. / 30min	kW	15 / 18.5 (22 / 26)				15 / 18.5 (22 / 26)	
MOTOR	Axis X/Y/Z/W/B	kW	4 / 4 / 4 / 4 / 4	4 / 4 / 4 / 4 / 7	4 / 4 / 4 / 4 / 4	4 / 4 / 4 / 4 / 7	4 / 7 / 4 / 4 / 4	
	Lubricator Motor	kW	0.15				0.15	
	Hydraulic Pump	kW	2.25				2.25	
	Coolant Pump	kW	1.17				1.17	
	Chip Conveyor	kW	0.2				0.2	
	Oil Cooler Pump	kW	0.75				0.75	
	No. of Tools	pieces	40 (60)				40 (60)	
ATC	Tool Selection		Absolute				Absolute	
	Tool Change Time	Sec.	15				15	
	Max. Tool-Diameter / Length	mm	Ø125/Ø250 (Without Adjacent Tool) / Length 400				Ø125/Ø250 (Without Adjacent Tool) / Length 400	
	Max. Tool Weight	kg	25				25	
	Max. Tool Length	mm	400				400	
COOLANT & LUBRICATION	Coolant Tank Volume	L	400				400	
	Hydraulic Tank Volume	L	80				80	
	Lubrication Tank Volume	L	8				8	
MISCELLANEOUS	Power Required	kVA	45				50	
	Pressurized Air	kg/cm ²	6				6	

■ Specifications are subject to change without prior notice.

STANDARD ACCESSORIES :

1. Linear scales on X, Y, Z axes
2. Spindle oil cooler
3. Automatic power off
4. Hydraulic system
5. Coolant system
6. Lubricator system
7. Alarm lamp
8. Work lamp
9. M.P.G.
10. RS232 interface
11. Heat exchanger
12. Chip conveyor and cart
13. Leveling bolts & pads
14. Controller manuals and circuit diagram
15. Operation manuals
16. Machine inspection lists
17. Splash guards (around the table)
18. Tool box
19. FANUC 0iMF
20. ATC : 40 Tools

OPTIONAL ACCESSORIES :

1. ATC: 60 Tools
2. Oil mist device
3. Variety of controllers (FANUC / MELDAS / SIEMENS / HEIDENHAIN)
4. Various auxiliary work tables
5. Air conditioner at the electrical cabinet
6. Extension sleeve 250mm/300mm
7. Coolant through spindle
8. Manual 90° angular milling head
9. Simultaneously controlled rotary table

KBM-110xxR SERIES

MOVABLE COLUMN

CNC HORIZONTAL BORING & MILLING MACHINE

- Movable column construction.
- Minimum deflection of spindle extension (W-axis).
- 0.001° indexing direct-drive rotary table. (0.001° simultaneously controlled rotary table is available)
- Table sizes 1400x1600mm. (Various types of table are optional)
- Two box ways on X-axis. (M65 roller type linear ways are optional)
- Two box ways on Y-axis with counter-balance weight. (2500mm of Y-axis travel is available)
- M65 roller type linear ways on Z-axis. (Three linear ways with 4 blocks on each way)
- Linear scales on 3 axes. (Heidenhain or Schneebberger brand)
- 40-tool magazine is standard. (60-tool or 90-tool magazine is optional)



※ **KBM-11025R**
Increased height of top guard
(optional)



Optimal Structure Design To Boost Stability

Rigid & Stable Structure

All structural parts are manufactured from high quality cast iron (FC30), tempered and stress relieved.

T-shape Base

The T-shape base construction allows the machine to be equipped with various table types.

The X-axis slideways are supported by double-wall cage-shape structure for ultra-high rigidity.

Guide Ways

Box ways on X and Y-axis.
Z-axis with 3 MRD65 SCHNEEBERGER roller type linear guide ways, featuring 12 blocks.

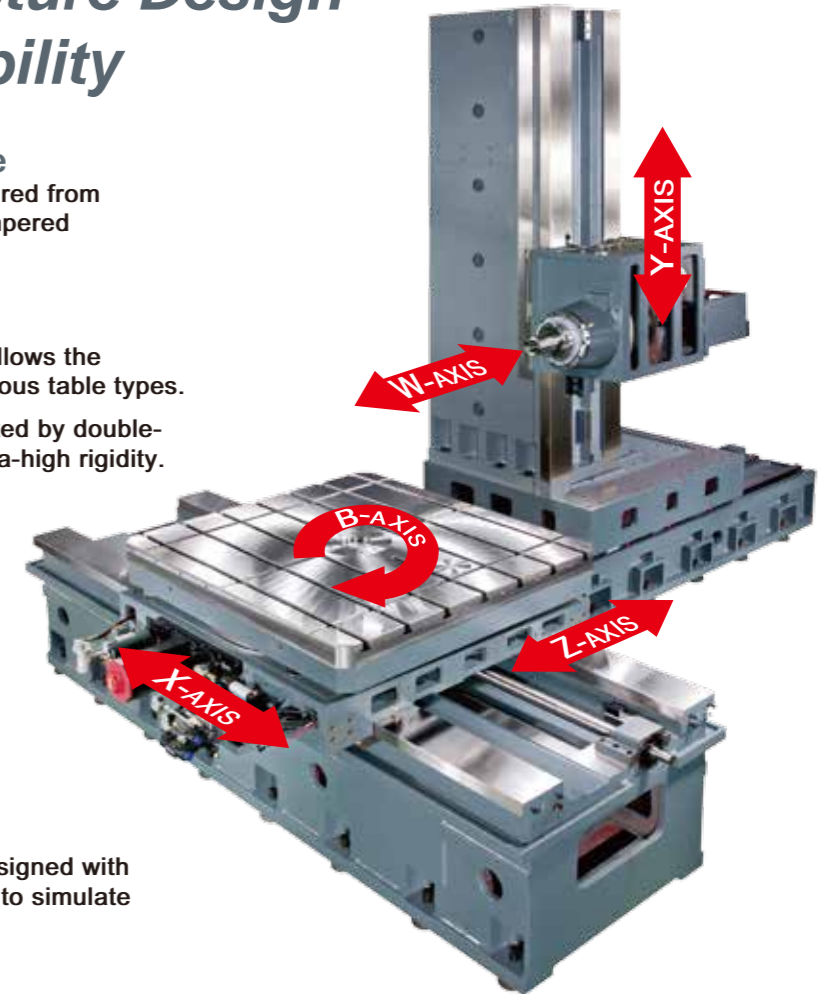

Finite Element Analysis (FEA)

The major structural parts are designed with Finite Element Analysis software to simulate stress/strain condition.



Rigid, Powerful Spindle Head

- The spindle head is reinforced with cage-shape ribs for increased rigidity.
- The KBM-110XXR series is designed with a self-made gearbox, having a 1:10 teeth ratio.

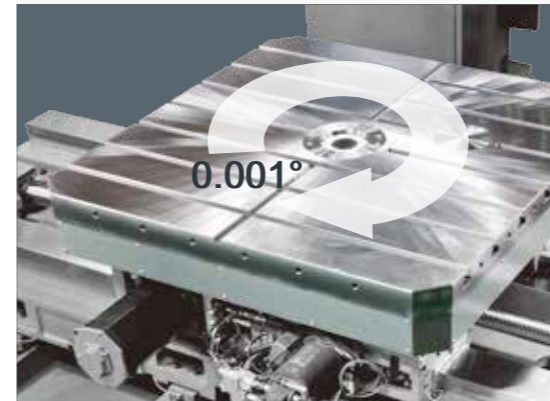
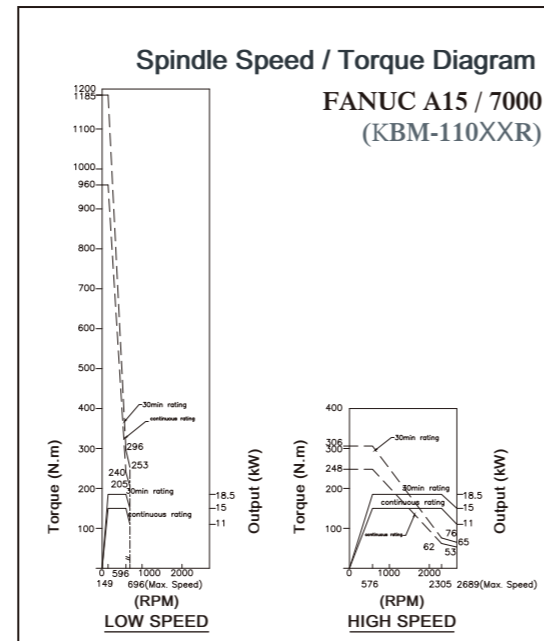

0.001° Rotary Table

- 0.001° indexing.
- 8 tons loading capacity on 1600 x 1400mm table.
- Available to equip with a 1800x1600mm table with 20 tons of loading capacity (optional)
- Each 90° positioning with dowel pin.
- Simultaneously controlled rotary table is available (optional).

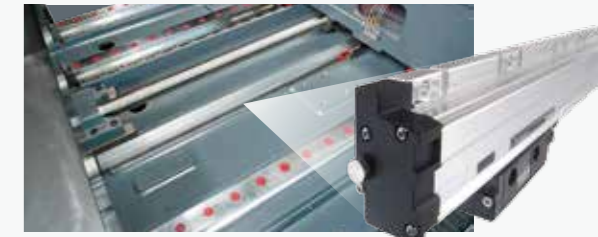

HEIDENHAIN Linear Scales on Three Axes (or Schneebberger)

X, Y, Z- axis are all equipped with linear scales to ensure high positioning accuracy.

KBM-110xxRT SERIES

MOVABLE COLUMN

CNC HORIZONTAL BORING & MILLING MACHINE

- Movable column construction.
- Minimum deflection of spindle extension (W-axis).
- 0.001° indexing direct-drive rotary table or long table. (Simultaneously controlled table is available)
- Table sizes 1400x1600mm. (Various types of table are optional)
- Two box ways on X-axis. (M65 roller type linear ways are optional)
- Two box ways on Y-axis with counter-balance weight.
- M65 roller type linear ways on Z-axis. (Three linear ways with 4 blocks on each way)
- Linear scales on 3 axes. (Heidenhain or Schneberger brand)
- 40-tool magazine is standard. (60-tool or 90-tool magazine is optional)

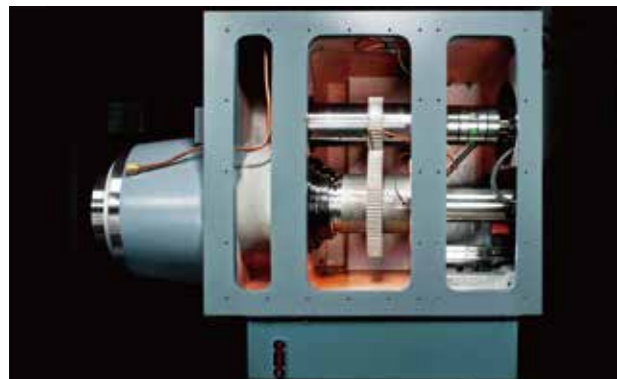

Rigid, Powerful Spindle Head

- The spindle head is reinforced with cage-shape ribs for increased rigidity.
- The spindle head integrates a self-made gearbox in combination with a German gearbox with 1: 8 teeth ratio, providing greater torque output in heavy cutting. (1:11 low speed teeth ratio is available)



Table of KBM-11025RT
1600x1400x0.001°
W-axis Travel 500mm



MACHINE SPECIFICATIONS () : As Optional

MODEL	UNIT	KBM-11020RT	KBM-11025RT	KBM-11032RT	KBM-11042RT	KBM-11020R	KBM-11025R	KBM-11032R	KBM-11042R
TABLE	Table Size	1400 x 1600 x 0.001°							
	T-slots Size	24 x 7							
	Maximum Load	8000							
TRAVEL	X-Axis	2000	2500	3200	4200	2000	2500	3200	4200
	Y-Axis	1800				2000 (2500)			
	Z-Axis	1700							
	W-Axis	500				550			
	Diameter	Ø110							
SPINDLE	Speed	0 ~ 2500 (3000, 4000)				0 ~ 2000 (2500)			
	Taper	7/24 taper ISO.50, BT-50							
DISTANCES	Spindle Center to Table	0~1800				0 ~ 2000 (2500)			
	Spindle Nose to Table Center	0~2200				0~2250			
	Height From Ground to Table Surface	1250							
FEED RATE	Rapid Feed Rate X/Y/Z	10							
	Rapid Feed Rate W	10							
	Minimum Setting	0.001							
	Cutting Feed Rate	1~5000							
MOTOR	Spindle Servo Motor-cont. / 30min	15 / 18.5 (22 / 26)							
	Axis X/Y/Z/W/B	7 / 4 / 4 / 4 / 7				7 / 7 / 7 / 4 / 7			
	Lubricator Motor	0.15							
	Hydraulic Pump	2.25							
	Coolant Pump	1.17							
	Chip Conveyor	0.2							
	Oil Cooler Pump	0.75							
ATC	No. of Tools	40 (60)							
	Tool Selection	Absolute							
	Tool Change Time	15							
	Max. Tool-Diameter / Length	Ø125/Ø250 (Without Adjacent Tool) / Length 400							
	Max. Tool Weight	25							
COOLANT & LUBRICATION	Coolant Tank Volume	400							
	Hydraulic Tank Volume	80							
	Lubrication Tank Volume	8							
MISCELLANEOUS	Power Required	55							
	Pressurized Air	kg/cm² 6							

■ Specifications are subject to change without prior notice.

STANDARD ACCESSORIES :

1. Linear scales on X, Y, Z axes
2. Spindle oil cooler
3. Automatic power off
4. Hydraulic system
5. Coolant system
6. Lubricator system
7. Alarm lamp
8. Work lamp
9. M.P.G.
10. RS232 interface
11. Heat exchanger
12. Chip conveyor and cart
13. Leveling bolts & pads
14. Controller manuals and circuit diagram
15. Operation manuals
16. Machine inspection lists
17. Splash guards (around the table)
18. Tool box
19. FANUC 0iMF
20. ATC : 40 Tools

OPTIONAL ACCESSORIES :

1. ATC: 60 tools
2. Oil mist device
3. Variety of controllers (FANUC / MELDAS / SIEMENS / HEIDENHAIN)
4. Various auxiliary work tables
5. Air conditioner at the electrical cabinet
6. Extension sleeve 250 / 300mm
7. Coolant through spindle
8. 1800x1600x0.001° rotary table (Table load 10 tons or 20 tons)
9. Manual 90° angular milling head
10. Simultaneously controlled rotary table

KBM-130xxRT SERIES

MOVABLE COLUMN

CNC HORIZONTAL BORING & MILLING MACHINE

- Movable column construction.
- Minimum deflection of spindle extension (W-axis).
- 0.001° indexing direct-drive rotary table or long table. (Simultaneously controlled table is available)
- Table sizes 1400x1600mm. (Various types of table are optional)
- Two box ways on X-axis. (M65 roller type linear ways are optional)
- Two box ways on Y-axis with counter-balance weight. (Choice of Y-axis travels: 2500, 3000, 3500mm)
- M65 roller type linear ways on Z-axis. (Three linear ways with 4 blocks on each way)
- Linear scales on 3 axes. (Heidenhain or Schneberger brand)
- 40-tool magazine is standard. (60-tool or 90-tool magazine is optional)

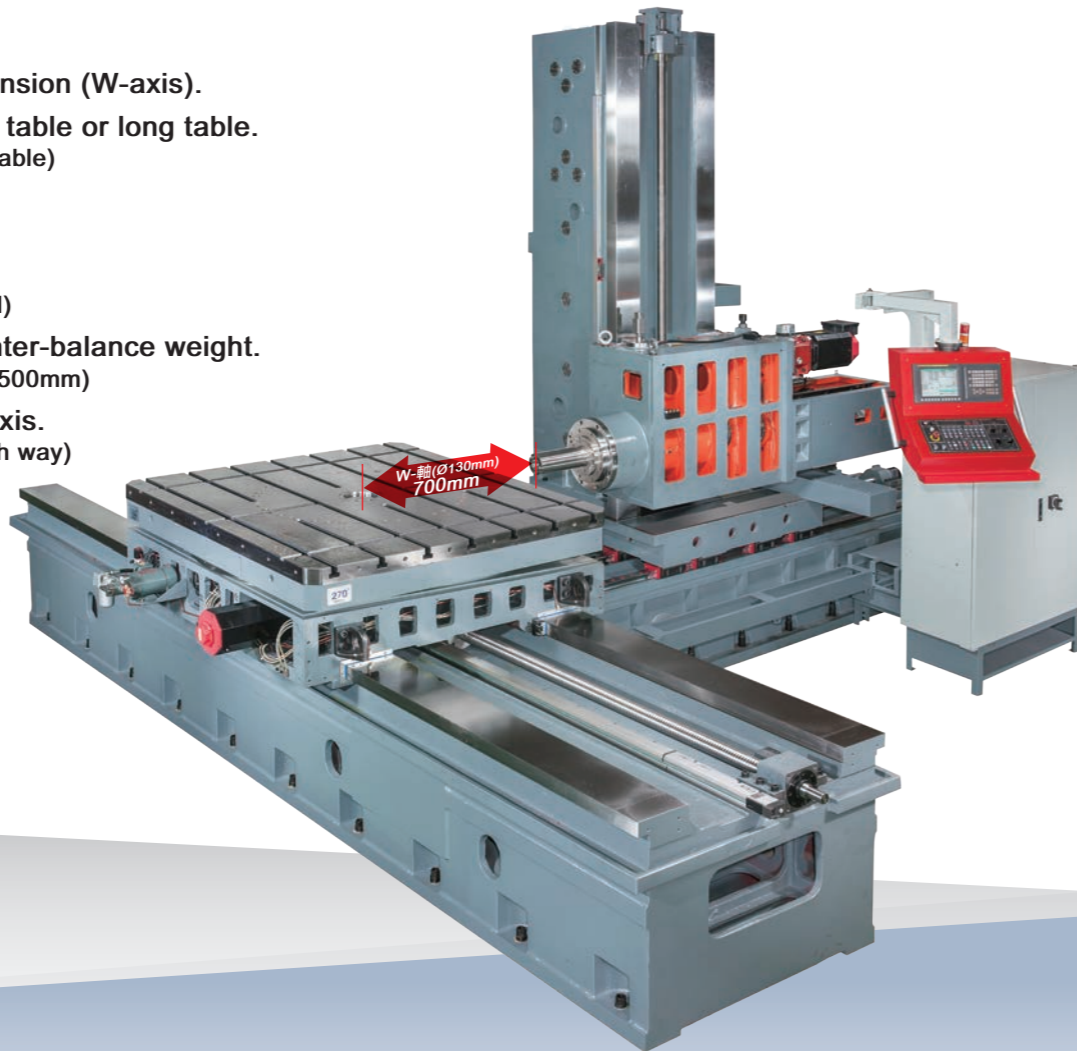

※ Fully enclosed splash guard (optional)

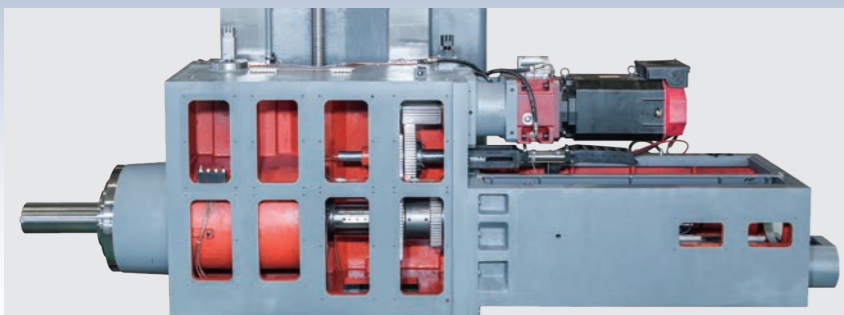

Rigid, Powerful Spindle Head

- The spindle head is reinforced with cage-shape ribs for increased rigidity.
- The spindle head integrates a self-made gearbox in combination with a German ZF gearbox with 1:16 (1:22 as optional) teeth ratio, providing greater torque output in heavy cutting.



Table of KBM-13025RT
1600x1400x0.001°
W-axis Travel 700mm



KBM-130xxR SERIES

MOVABLE COLUMN

CNC HORIZONTAL BORING & MILLING MACHINE

- Germany imported high rigidity, high accuracy spindle.
- Spindle diameter $\varnothing 130\text{mm}$. Spindle extension (W-axis) is 700mm (Standard). (900mm optional).
- 1800mmx2000mmx0.001° direct-drive rotary table. (Various types of table are optional)
- Two box ways on X-axis. (M65 roller type linear ways are optional)
- Two box ways on Y-axis with counter-balance weight. (Choice of Y-axis travels: 3000 and 3500mm)
- M65 roller type linear ways on Z-axis. (Three linear ways with 4 blocks on each way)
- Linear scales on 3 axes. (Heidenhain or Schneberger brand)
- 40-tool magazine is standard. (60-tool or 90-tool magazine is optional)

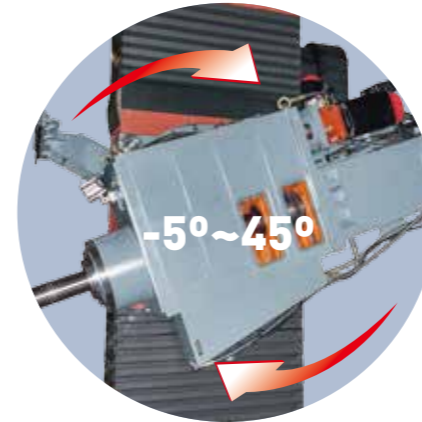

Swiveling head -5°~45° (Optional)



Face milling head (Optional)



KBM-W
series

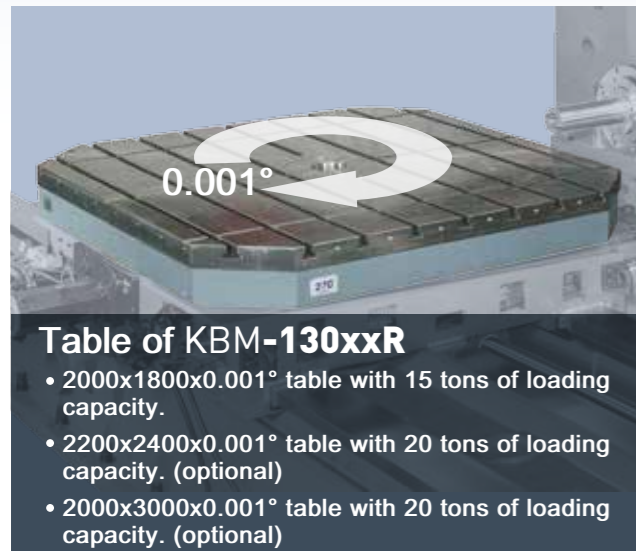
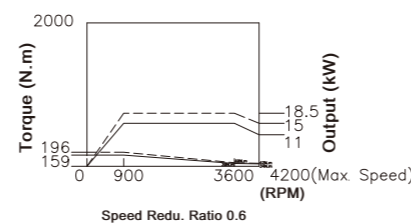
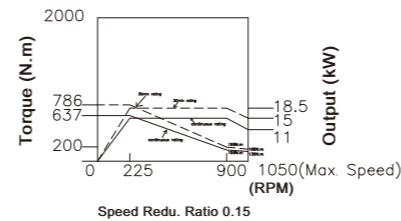
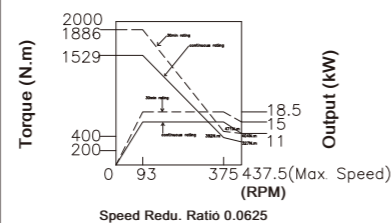

Table of KBM-130xxR

- 2000x1800x0.001° table with 15 tons of loading capacity.
- 2200x2400x0.001° table with 20 tons of loading capacity. (optional)
- 2000x3000x0.001° table with 20 tons of loading capacity. (optional)

Spindle Speed / Torque Diagram FANUC A15 / 7000 (KBM-130XXR)



- ※ 3 linear ways on X-axis (Optional for KBM-130xxR)
- Standard accessory for model KBM-130xxRL
- Standard accessory for model KBM-150xxRL

MACHINE SPECIFICATIONS

[]: As Optional

MODEL		UNIT	KBM-13020RT	KBM-13025RT	KBM-13032RT	KBM-13042RT	KBM-13032R	KBM-13042R	KBM-13052R
TABLE	Table Size	mm	1600 x 1400 x 0.001°				1800 x 2000 x 0.001°		
	T-slots Size	mm	24 x 7				28 x 9		
	Maximum Load	kg	8000				15000 (20000)		
TRAVEL	X-Axis	mm	2000	2500	3200	4200	3200	4200	5200
	Y-Axis	mm	2000 (2500, 3000)				(2000) 2500 (3000)		
	Z-Axis	mm	2000 (2500)				2000 (2500)		
	W-Axis	mm	700 (900)				700 (900)		
SPINDLE	Diameter	mm	Ø130				Ø130		
	Speed	rpm	10 ~ 2000 (2500) (3000)				10 ~ 2000 (2500) (3000)		
DISTANCES	Taper		7/24 taper ISO.50, BT-50				7/24 taper ISO.50, BT-50		
	Spindle Center to Table	mm	0~2000 (0~2500, 0~3000)				(0~2000) 0~2500 (0~3000)		
	Spindle Nose to Table Center	mm	-150~2250				50~2750		
FEED RATE	Height From Ground to Table Surface	mm	1260				1520		
	Rapid Feed Rate X/Y/Z	m/min	10				10		
	Rapid Feed Rate W	m/min	6				6		
	Minimum Setting	mm/min	0.001				0.001		
	Cutting Feed Rate	mm/min	1~5000				1~5000		
MOTOR	Spindle Servo Motor-cont. / 30min	kW	15 / 18.5 (22 / 26)				15 / 18.5 (22 / 26)		
	Axis X/Y/Z/W/B	kW	7/7/7/4/7				9/7/9/4/7		
	Lubricator Motor	kW	0.15				0.15		
	Hydraulic Pump	kW	2.25				2.25		
	Coolant Pump	kW	1.17				1.17		
	Chip Conveyor	kW	0.2				0.2		
	Oil Cooler Pump	kW	0.75				0.75		
ATC	No. of Tools	pieces	40 (60)				40 (60)		
	Tool Selection		Absolute				Absolute		
	Tool Change Time	Sec.	15				15		
	Max. Tool-Diameter / Length	mm	Ø125/Ø250 (Without Adjacent Tool) / Length 400				Ø125/Ø250 (Without Adjacent Tool) / Length 400		
COOLANT & LUBRICATION	Max. Tool Weight	kg	25				25		
	Coolant Tank Volume	L	400				400		
	Hydraulic Tank Volume	L	80				80		
MISCELLANEOUS	Lubrication Tank Volume	L	8				8		
	Power Required	kVA	55				55		
	Pressurized Air	kg/cm ²	6				6		

■ Specifications are subject to change without prior notice.

STANDARD ACCESSORIES :

- | | | |
|----------------------------------|--|--------------------------------------|
| 1. Linear scales on X, Y, Z axes | 9. M.P.G. | 17. Splash guards (around the table) |
| 2. Spindle oil cooler | 10. RS232 interface | 18. Tool box |
| 3. Automatic power off | 11. Heat exchanger | 19. FANUC 0iMF |
| 4. Hydraulic system | 12. Chip conveyor and cart | 20. ATC : 40 Tools |
| 5. Coolant system | 13. Leveling bolts & pads | |
| 6. Lubricator system | 14. Controller manuals and circuit diagram | |
| 7. Alarm lamp | 15. Operation manuals | |
| 8. Work lamp | 16. Machine inspection lists | |

MACHINE SPECIFICATIONS

[]: As Optional

MODEL		UNIT	KBM-13032RL	KBM-13042RL	KBM-13052RL	KBM-13062RL	KBM-15032RL	KBM-15042RL	KBM-15052RL	KBM-15062RL
TABLE	Table Size	mm	2200 x 2500 x 0.001° (2500 x 3000 x 0.001°)				2200 x 2500 x 0.001° (2500 x 3000 x 0.001°)			
	T-slots Size	mm	28 x 11 (28 x 13)				28 x 11 (28 x 13)			
	Maximum Load	kg	30000 (40000)				30000 (40000)			
TRAVEL	X-Axis	mm	3200	4200	5200	6200	3200	4200	5200	6200
	Y-Axis	mm	2500 (3000, 3500)				2500 (3000, 3500)			
	Z-Axis	mm	2000 (2500)				2000 (2500)			
	W-Axis	mm	900				900			
SPINDLE	Diameter	mm	Ø130				Ø150			
	Speed	rpm	10 ~ 2000 (2500) (3000)				10 ~ 1500 (2000)			
DISTANCES	Taper		7/24 taper ISO.50, BT-50				7/24 taper ISO.50, BT-50			
	Spindle Center to Table	mm	0~2500 (0~3000) (0~3500)				0~2500 (0~3000) (0~3500)			
	Spindle Nose to Table Center	mm	-50~2850 (3350) {50~2950 (3450)}				-50~2850 (3350) {50~2950 (3450)}			
FEED RATE	Height From Ground to Table Surface	mm	1520				1520			
	Rapid Feed Rate X/Y/Z	m/min	8 / 10 / 10 (6 / 10 / 10)				8 / 10 / 10 (6 / 10 / 10)			
	Rapid Feed Rate W	m/min	6				6			
	Minimum Setting	mm/min	0.001				0.001			
	Cutting Feed Rate	mm/min	1~5000				1~5000			
MOTOR	Spindle Servo Motor-cont. / 30min	kW	22 / 26 (30 / 37)				22 / 26 (30 / 37)			
	Axis X/Y/Z/W/B	kW	9/7/9/4/9				9/7/9/4/9			
	Lubricator Motor	kW	0.15				0.15			
	Hydraulic Pump	kW	2.25				2.25			
	Coolant Pump	kW	1.17				1.17			
	Chip Conveyor	kW	0.2				0.2			
	Oil Cooler Pump	kW	0.75				0.75			
ATC	No. of Tools	pieces	40 (60)				40 (60)			
	Tool Selection		Absolute				Absolute			
	Tool Change Time	Sec.	15				15			
	Max. Tool-Diameter / Length	mm	Ø125/Ø250 (Without Adjacent Tool) / Length 400				Ø125/Ø250 (Without Adjacent Tool) / Length 400			
COOLANT & LUBRICATION	Max. Tool Weight	kg	25				25			
	Coolant Tank Volume	L	400				400			
	Hydraulic Tank Volume	L	80				80			
MISCELLANEOUS	Lubrication Tank Volume	L	8				8			
	Power Required	kVA	65				65			
	Pressurized Air	kg/cm ²	6				6			

■ Specifications are subject to change without prior notice.

OPTIONAL ACCESSORIES :

- | | | |
|--|--|--|
| 1. Choice of various magazines (60 / 90) | 6. Extension sleeve 250 / 300mm (For KBM-110 series) | 9. Manual 90° angular milling head |
| 2. Oil mist device | Extension sleeve 350 / 400mm (For KBM-130 series, KBM-150 series) | 10. Face milling head |
| 3. Choice of various controllers (FANUC / MELDAS / SIEMENS / HEIDENHAIN) | 7. Coolant through spindle | 11. 30/37kW spindle motor and ZF-300 gearbox (For KBM-130, 150 series) |
| 4. Various auxiliary work tables | 8. Choice of various sizes of tables | |
| 5. Air conditioner at the electrical cabinet | <ul style="list-style-type: none"> ■ 1600x1800 (For KBM-110xxRT, 110xxR, 130xxRT series) ■ 2000x2200 / 2000x3000 / 2200x2400 (For KBM-130xxR series) ■ 2500x3000 table with 40 tons of loading capacity (For KBM-130xxRL, 150xxRL series) | |

KBM-LONG TABLE SERIES

MOVABLE COLUMN

CNC HORIZONTAL BORING & MILLING MACHINE

- Movable column construction.
- Minimum deflection of spindle extension (W-axis).
- Long type heavy duty table.
- Rigid roller type linear ways on X, Z-axis.
- 40-tool magazine is standard. (60-tool magazine optional)
- Integrated Schneberger linear ways and linear scales on X, Y, Z-axis.

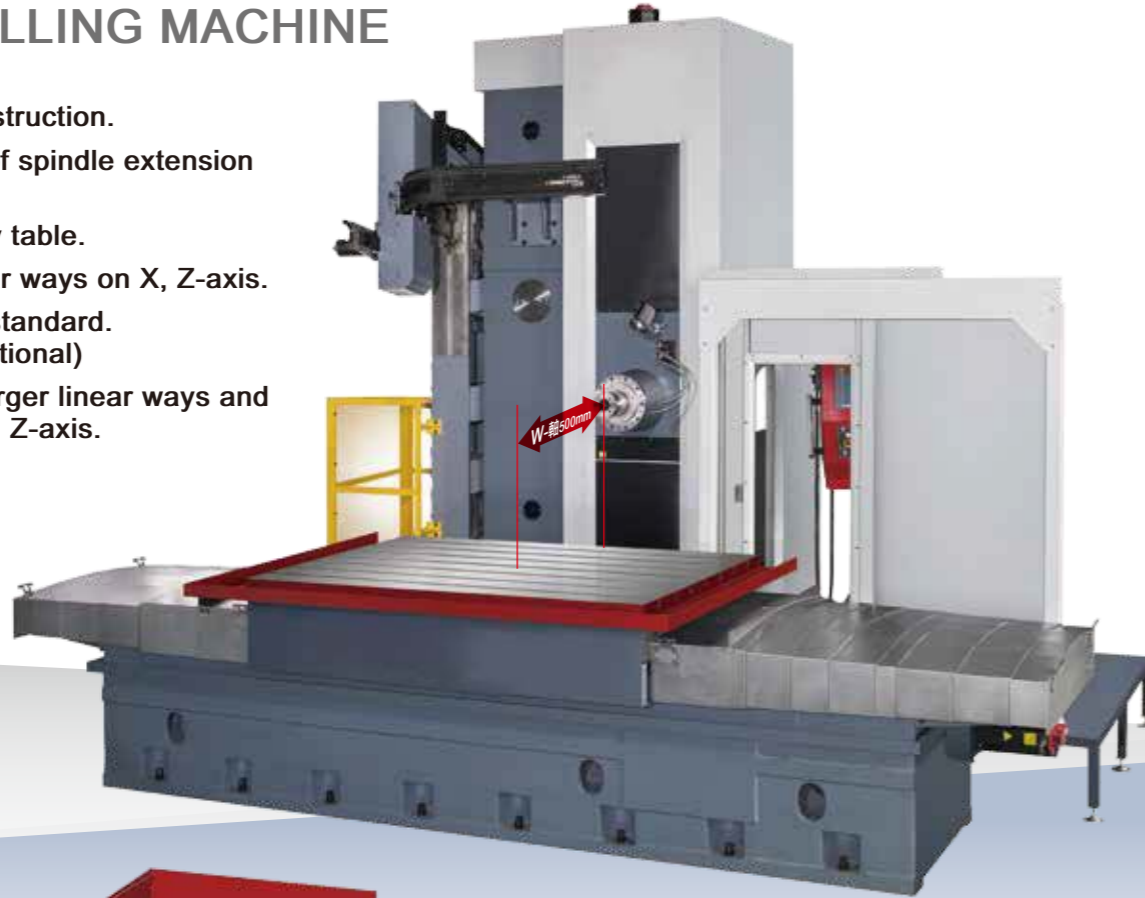

KBM-13042 KBM-13052 KBM-13062

- Heavy duty table (4000x2500, 5000x2500, 6000x2500mm).
- 4 linear ways on X-axis (M65 roller type).
- X-axis feed is transmitted through precision rack (KBM-13052, 13062).
- Integrated Schneberger linear ways and linear scales on X, Y, Z-axis.



※ Extra rigid base can withstand heavy load up to 60 tons

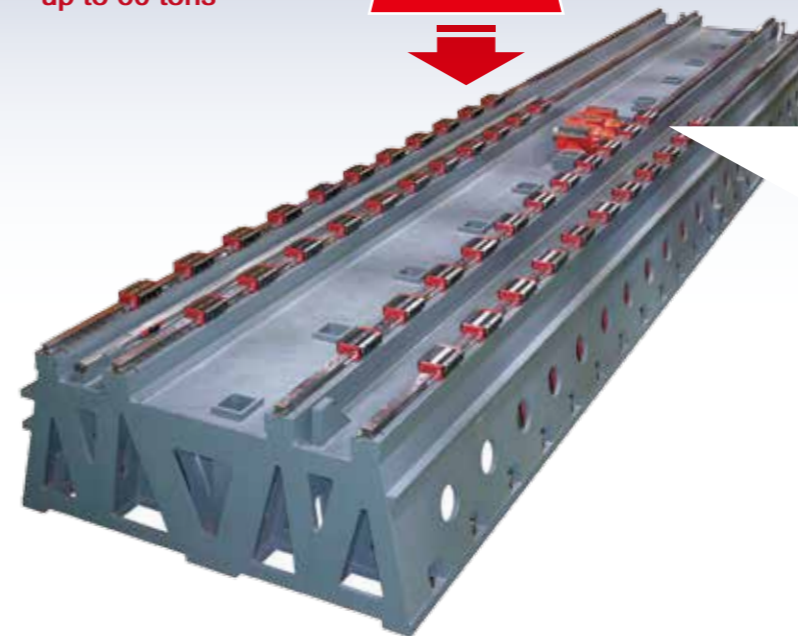

High precision rack and twin speed reducers transmission.
(For models KBM-13052, 13062)



※ Fully enclosed splash guard (optional)

MACHINE SPECIFICATIONS

[] : As Optional

MODEL		UNIT	KBM-11022T	KBM-11026T	KBM-11032T	KBM-11042T	KBM-11022	KBM-11026	KBM-11032	KBM-11042	KBM-13032	KBM-13042	KBM-13052	KBM-13062	KBM-13072
TABLE	Table Size	mm	2000 x 1400	2400 x 1400	3000 x 1400	4000 x 1400	2000 x 1400	2400 x 1400	3000 x 1400	4000 x 1400	3000 x 1400	4000 x 2500	5000 x 2500	6000 x 2500	7000 x 2500
	T-slots Size	mm	22				22				22	28			
	Maximum Load	kg	12000	15000	20000	25000	12000	15000	20000	25000	20000	30000	40000	50000	50000
TRAVEL	X-Axis	mm	2200	2600	3200	4200	2200	2600	3200	4200	3200	4200	5200	6200	7200
	Y-Axis	mm	1800				2000 (2500)				2500 (3000) (3500)				
	Z-Axis	mm	1700				1700				2000 (2500)				
	W-Axis	mm	500				550				700 (900)				
SPINDLE	Diameter	mm	Ø110				Ø110				Ø130				
	Speed	rpm	10 ~ 2500 (3000) (4000)				10 ~ 2500				10 ~ 2000 (2500) (3000)				
	Taper		7/24 taper ISO.50, BT-50				7/24 taper ISO.50, BT-50				7/24 taper ISO.50, BT-50				
DISTANCES	Spindle Center to Table	mm	0~1800				0~2000 (2500)				0~2500 (3000) (3500)				
	Spindle Nose to Table Center	mm	-50~2150				-100~2150				-250~2150	200~2900 (0~2900)			
	Height From Ground to Table Surface	mm	1180				1180				1180	1520			
FEED RATE	Rapid Feed Rate X/Y/Z	m/min	10				10				10	6 / 10 / 10			
	Rapid Feed Rate W	m/min	10				10				10	6			
	Minimum Setting	mm/min	0.001				0.001				0.001				
	Cutting Feed Rate	mm/min	1~5000				1~5000				1~5000				
MOTOR	Spindle Servo Motor-cont. /30min	kW	15 / 18.5 (22 / 26)				15 / 18.5 (22 / 26)				15 / 18.5 (22 / 26)				
	Axis X/Y/Z/W/B	kW	7 / 4 / 4 / 4				7 / 7 / 7 / 4				9 / 7 / 7 / 4	9 / 7 / 9 / 4		9 / 9 / 7 / 4	
	Lubricator Motor	kW	0.15				0.15				0.15				
	Hydraulic Pump	kW	2.25				2.25				2.25				
	Coolant Pump	kW	1.17				1.17				1.17				
	Chip Conveyor	kW	0.2				0.2				0.2				
	Oil Cooler Pump	kW	0.75				0.75				0.75				
ATC	No. of Tools	pieces	40 (60)				40 (60)				40 (60)				
	Tool Selection		Absolute				Absolute				Absolute				
	Tool Change Time	Sec.	15				15				15				
	Max. Tool-Diameter / Length	mm	Ø125/Ø250 (Without Adjacent Tool) / Length 400				Ø125/Ø250 (Without Adjacent Tool) / Length 400				Ø125/Ø250 (Without Adjacent Tool) / Length 400				
	Max. Tool Weight	kg	25				25				25				
COOLANT & LUBRICATION	Coolant Tank Volume	L	400				400				400				
	Hydraulic Tank Volume	L	80				80				80				
	Lubrication Tank Volume	L	8				8				8				
MISCELLANEOUS	Power Required	kVA	55				55				55				
	Pressurized Air	kg/cm ²	6				6				6				

■ Specifications are subject to change without prior notice.

STANDARD ACCESSORIES :

- | | |
|----------------------------------|--|
| 1. Linear scales on X, Y, Z axes | 11. Heat exchanger |
| 2. Spindle oil cooler | 12. Chip conveyor and cart |
| 3. Automatic power off | 13. Leveling bolts & pads |
| 4. Hydraulic system | 14. Controller manuals and circuit diagram |
| 5. Coolant system | 15. Operation manuals |
| 6. Lubricator system | 16. Machine inspection lists |
| 7. Alarm lamp | 17. Splash guards (around the table) |
| 8. Work lamp | 18. Tool box |
| 9. M.P.G. | 19. FANUC 0iMF |
| 10. RS232 interface | 20. ATC : 40 Tools |

OPTIONAL ACCESSORIES :

- ATC: 60 tools
- Oil mist device
- Variety of controllers (FANUC / MELDAS / SIEMENS / HEIDENHAIN)
- Various auxiliary work tables
- Air conditioner at the electrical cabinet
- Extension sleeve 250mm / 300mm
- Coolant through spindle
- Manual 90° angular milling head
- Splash guard around table and large external splash guard



Side-mount Chain Type Magazine

- 40 - tool magazine is standard.
- 60 - tool magazine is optional.



Extension Sleeve (Optional)



Manual 90° Degree Milling Head (Optional)

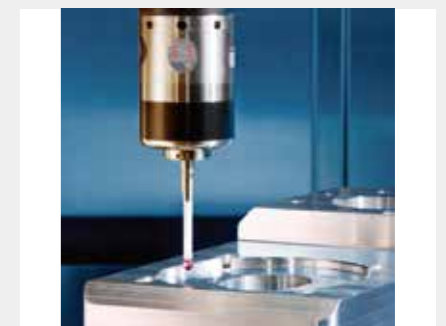

Work Piece Coordinate Measuring (m&h RWP38.41) (RENISHAW RMP60) (Optional)



Auto. Tool Length & Diameter Measurement (m&h TS35.10) (RENISHAW RTS-27) (Optional)