

Company / customer EPLAN

Project description

Job number KUG-NC1 (J4

Commission CE) V4.0

Manufacturer (company)

Path Pages and devices, sequential numbering

Project name KUG-NC1 (220 J4 CE)

Make Centerless Gringing

Type DC2V

Place of installation

Responsible for project

Part feature Sonderlackierung

Created on 2009/7/30

Edit date 2024/11/4 by (short name) 8143

Number of pages 22

			Date	2024/11/4	V4.0		封面		=
			Ed.	8143					+
			Appr						
Modification	Date	Name	Original		Replacement of	Replaced by		KUG-NC1 (J4 CE)	Page 1 / 22

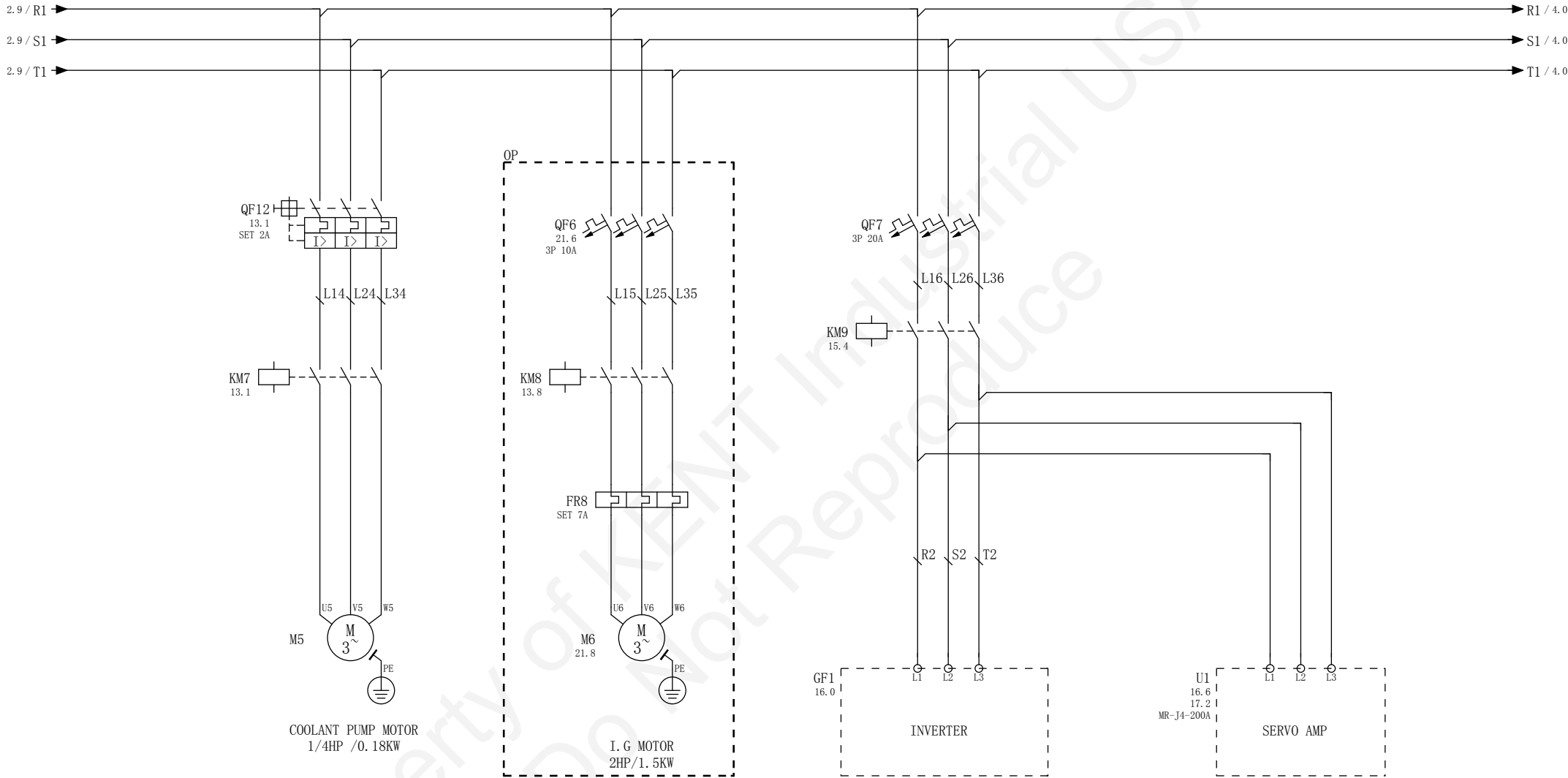

		Date	2023/7/19	V4.0			MAIN CIRCUIT			=
		Ed.	8143							+
		Appr								
Modification	Date	Name	Original	Replacement of	Replaced by			KUG-NC1 (J4 CE)	Page	3
									Page	3/22

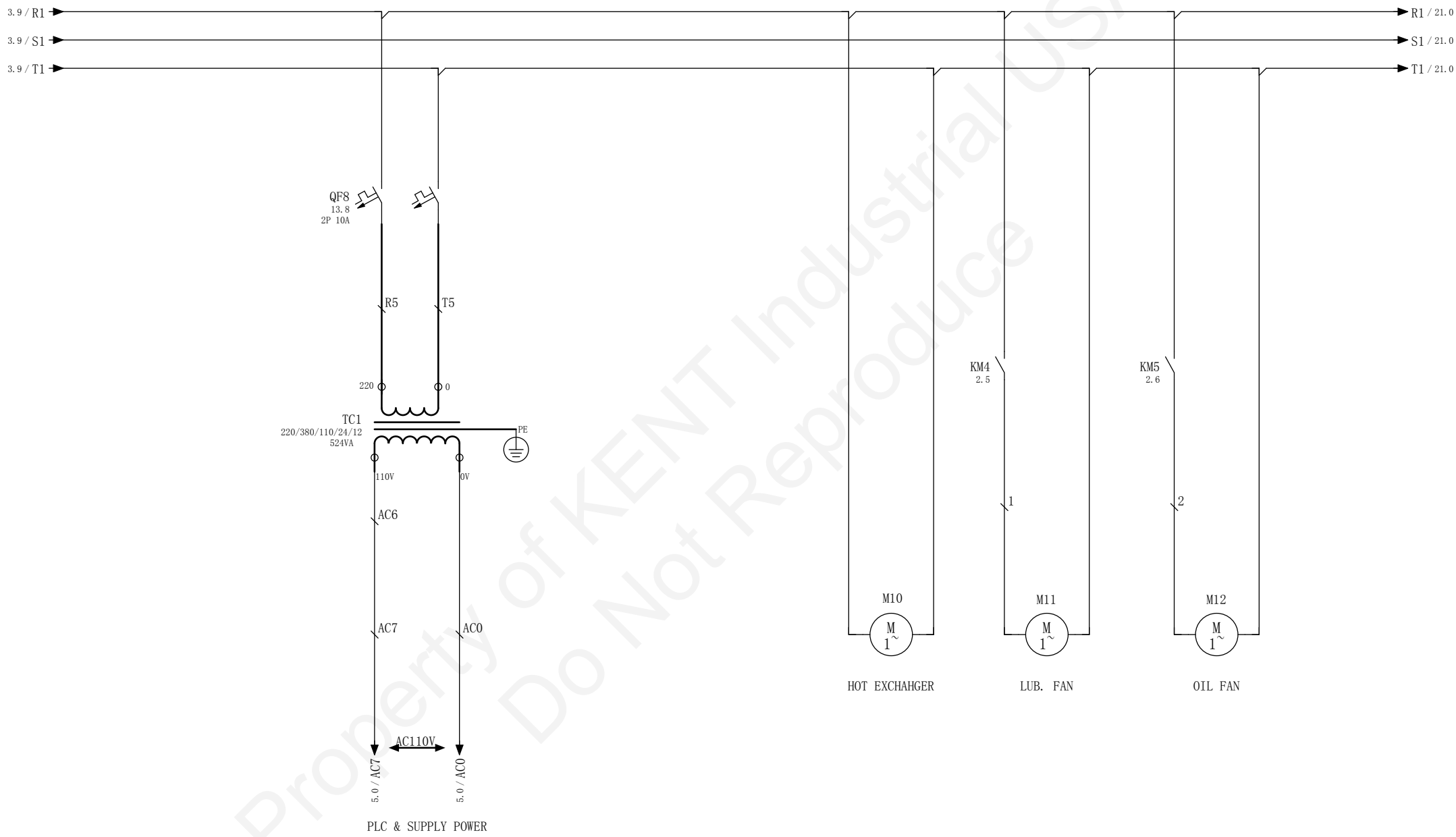

		Date	2023/7/19	V4.0		MAIN CIRCUIT			
		Ed.	8143						
		Appr							
Modification	Date	Name	Original	Replacement of	Replaced by			KUG-NC1 (J4 CE)	Page 4
								Page	4/22

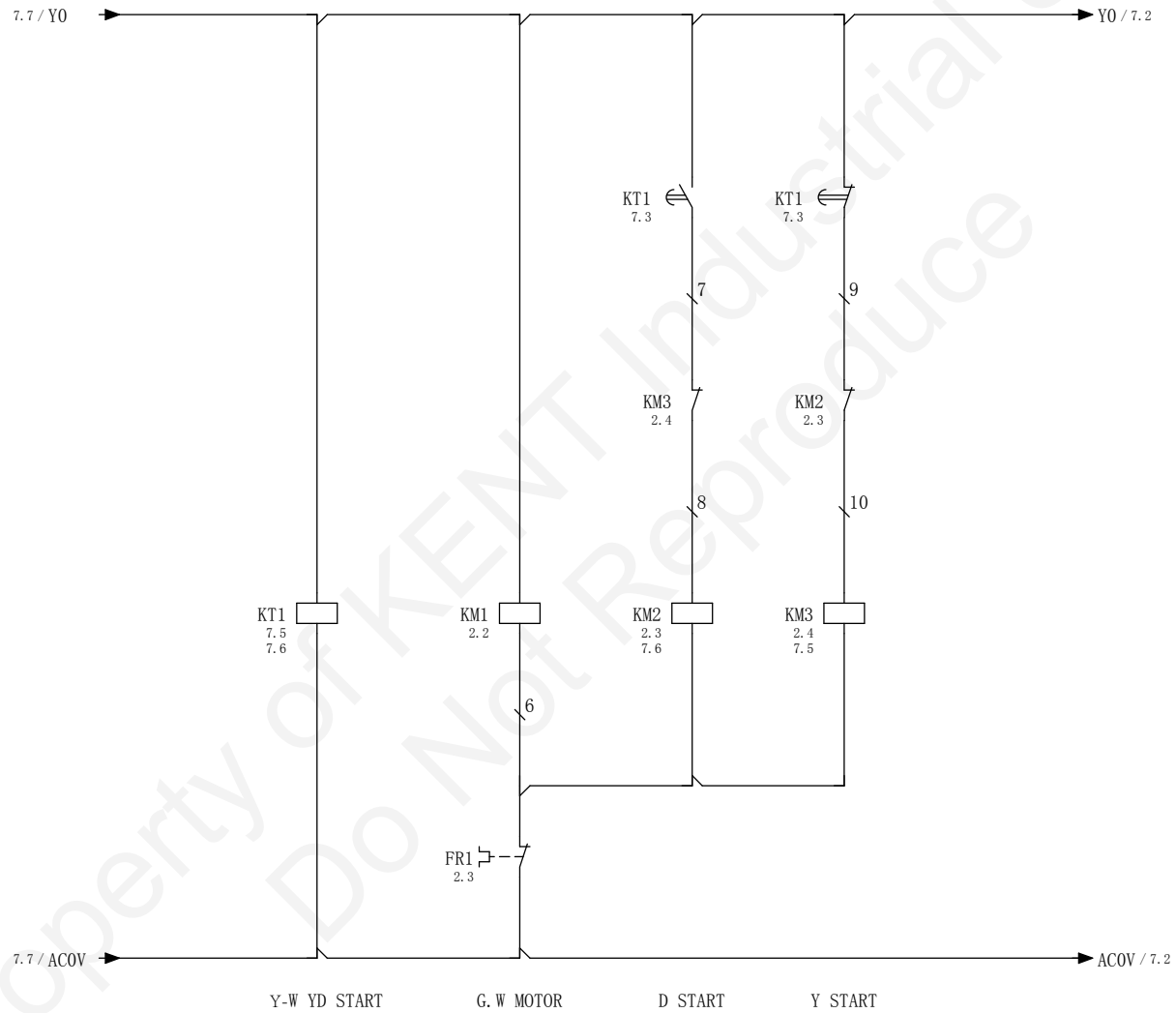

Property of KENT Industrial USA
Do Not Reproduce

		Date	2021/5/13	V4.0		DC CONTROL CIRCUIT		=	
		Ed.	8143					+	
		Appr							
Modification	Date	Name	Original	Replacement of	Replaced by			KUG-NC1 (J4 CE)	Page 7 / 22

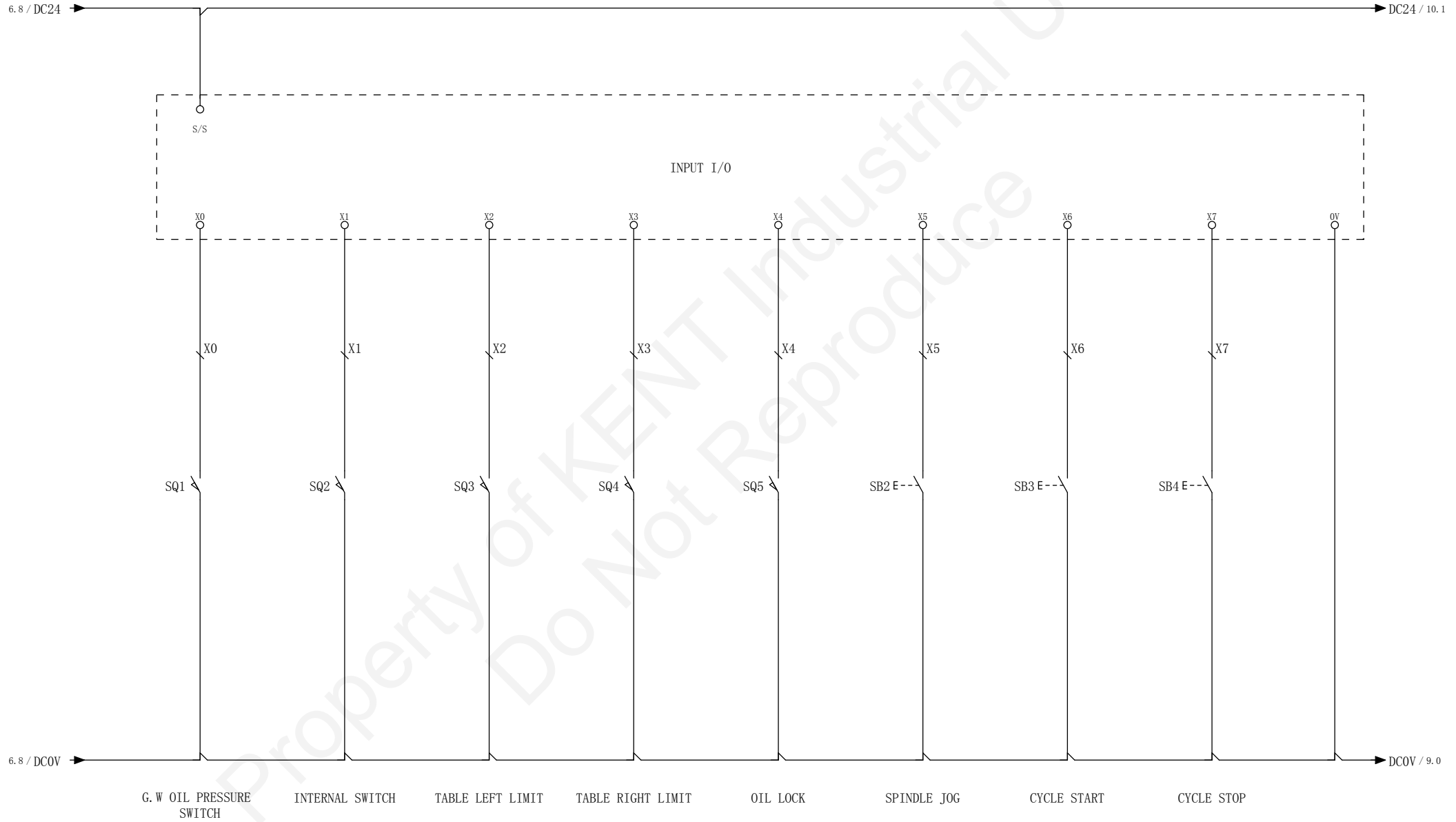

		Date	2023/7/19	V4.0		INPUT CIRCUIT X0		=	
		Ed.	8143					+	
		Appr							
Modification	Date	Name	Original	Replacement of	Replaced by			KUG-NC1 (J4 CE)	Page 8 / 22

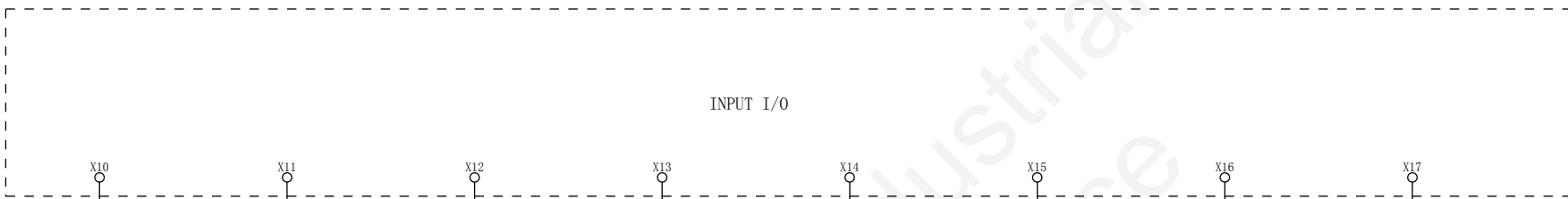

8										10	
		Date	2021/4/29	V4.0		INPUT CIRCUIT X10				=	
		Ed.	8143							+	
		Appr									
Modification	Date	Name	Original	Replacement of	Replaced by			KUG-NC1 (J4 CE)		Page	9
										Page	9 / 22

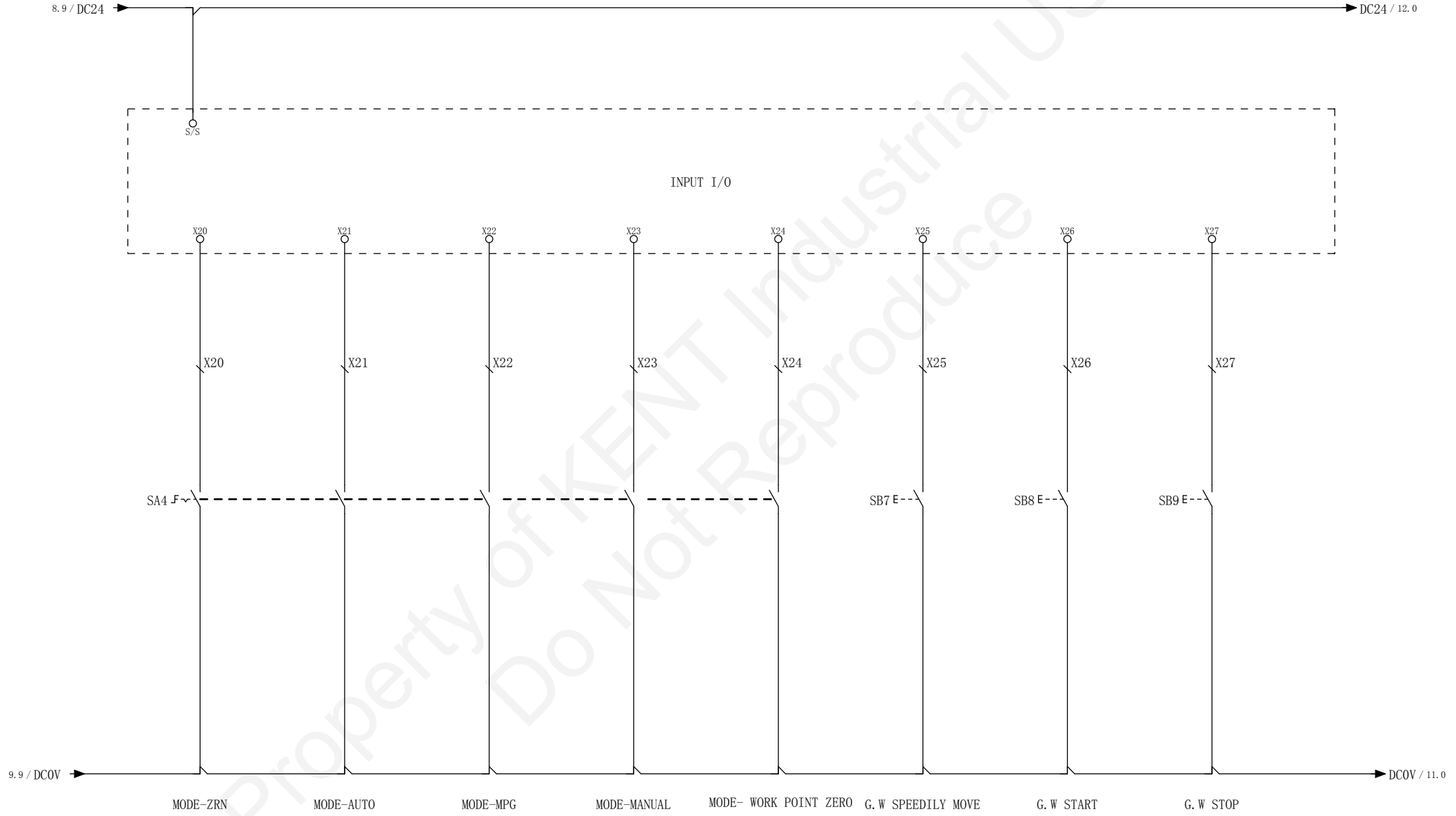

		Date	2020/4/9	V4.0		INPUT CIRCUIT X20		=	
		Ed.	8143					+	
		Appr							
Modification	Date	Name	Original	Replacement of	Replaced by			KUG-NC1 (J4 CE)	Page 10
									Page 10/22

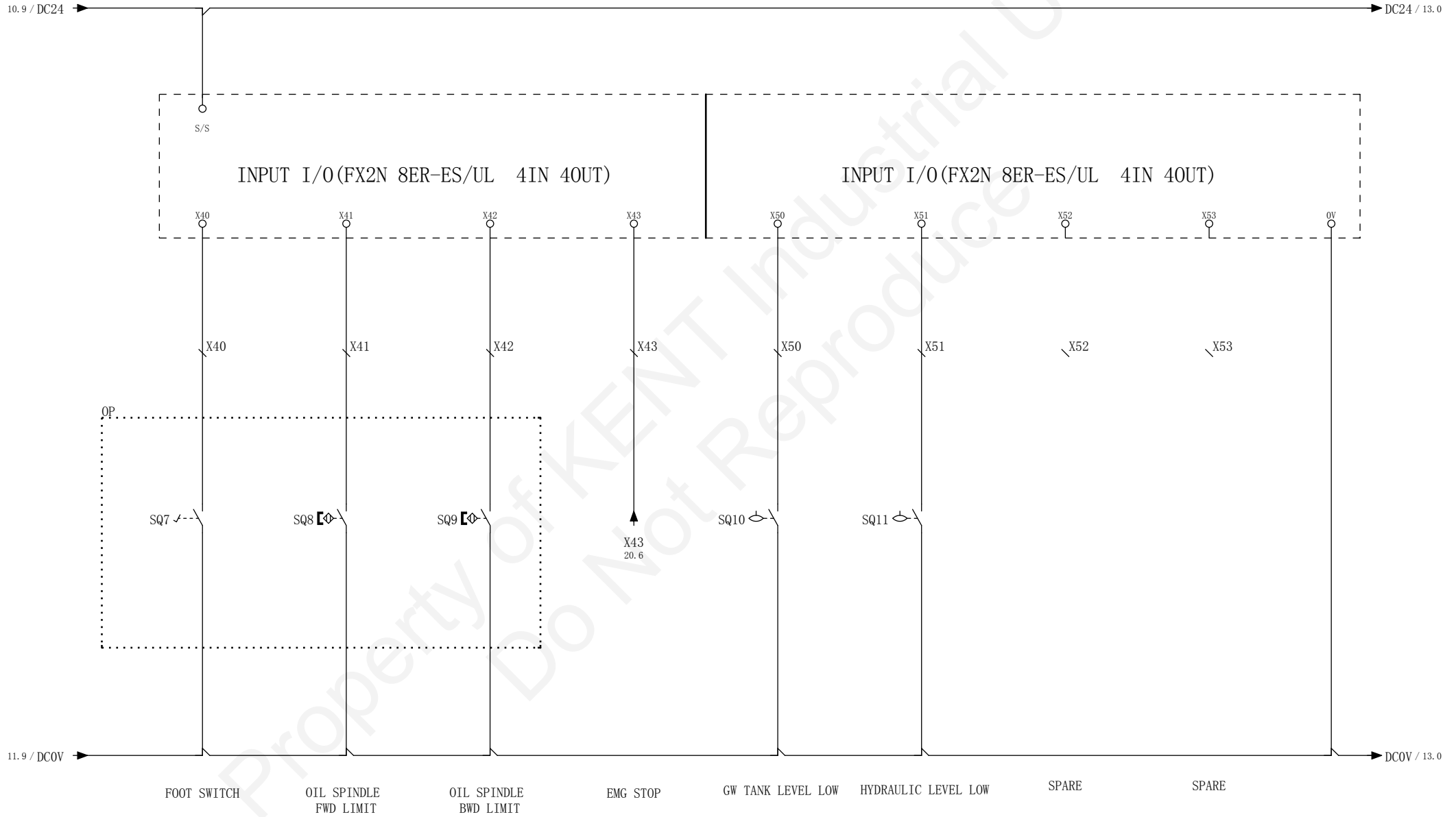

		Date	2023/7/19	V4.0		INPUT CIRCUIT X40		=	
		Ed.	8143					+	
		Appr							
Modification	Date	Name	Original	Replacement of	Replaced by			KUG-NC1 (J4 CE)	Page 12 / 22

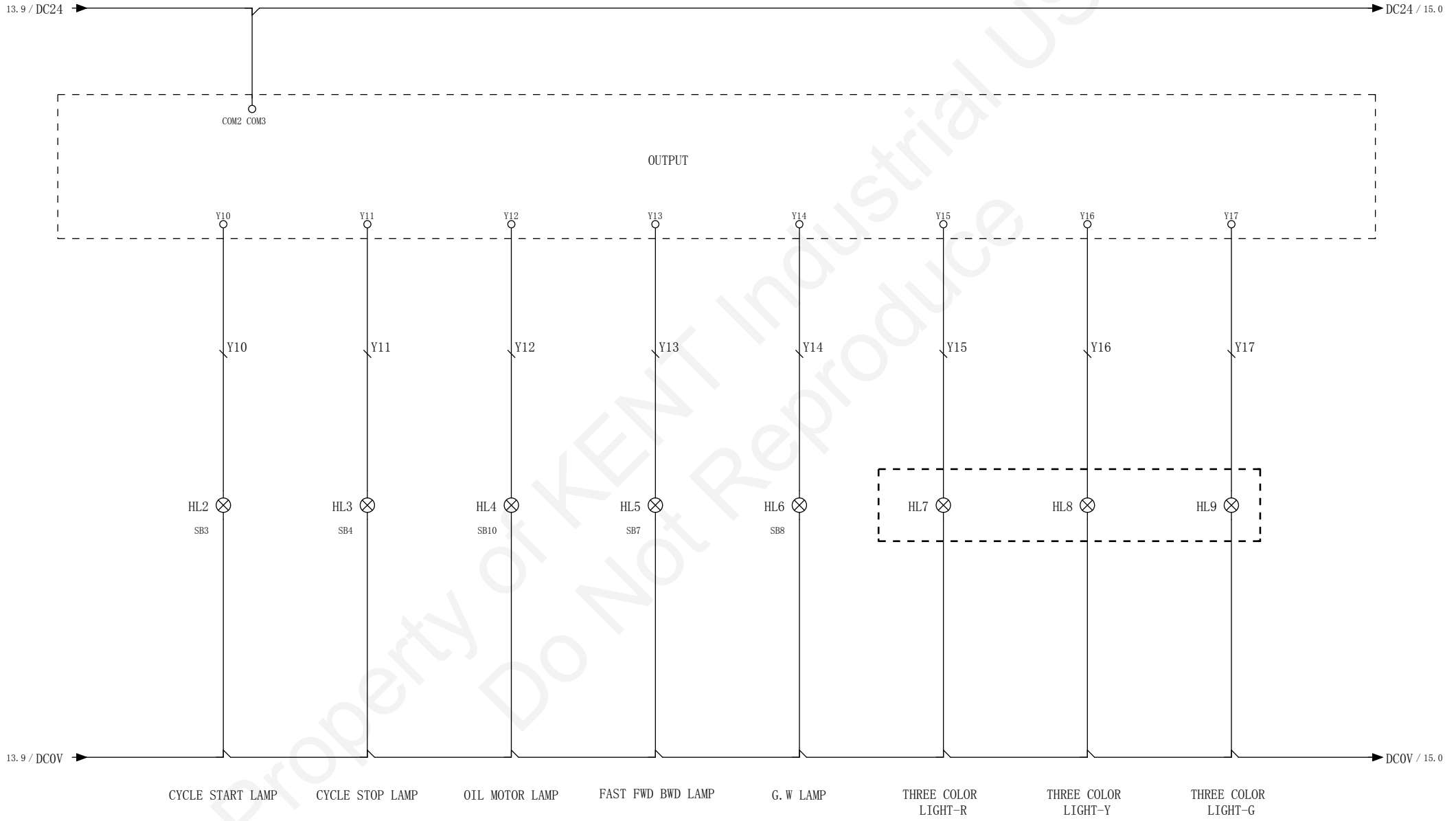

		Date	2021/9/16	V4.0			OUTPUT CIRCUIT Y10			=
		Ed.	8143							+
		Appr								
Modification	Date	Name	Original	Replacement of	Replaced by			KUG-NC1 (J4 CE)	Page	14
									Page	14/22

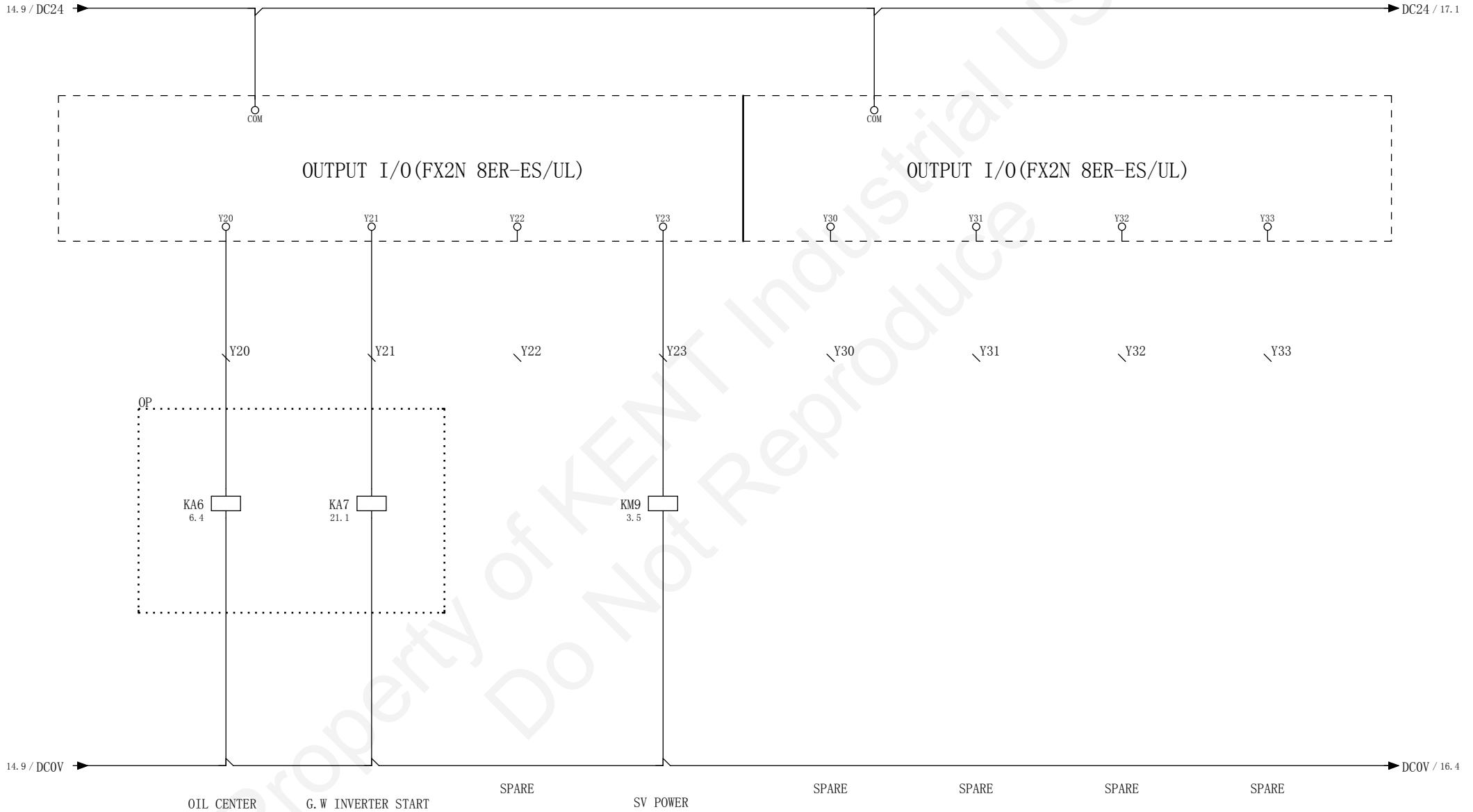

		Date	2021/9/16	V4.0			OUTPUT CIRCUIT Y20	=
		Ed.	8143					+
		Appr						
Modification	Date	Name	Original	Replacement of	Replaced by	KUG-NC1 (J4 CE)		Page 15
								Page 15/22

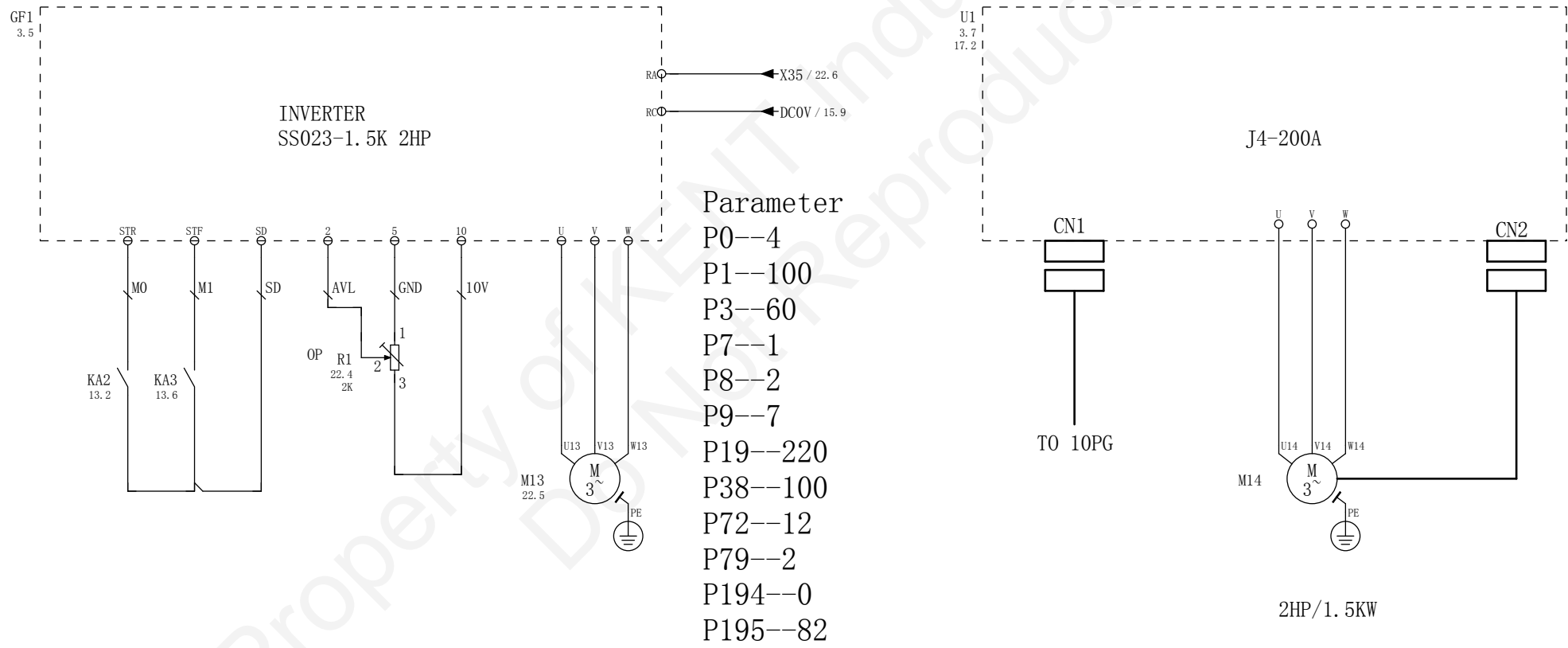

		Date	2023/7/19	V4.0		INVERTER CONECTION CIRCUIT			
		Ed.	8143						
		Appr							
Modification	Date	Name	Original	Replacement of	Replaced by			KUG-NC1 (J4 CE)	Page 16 / 22

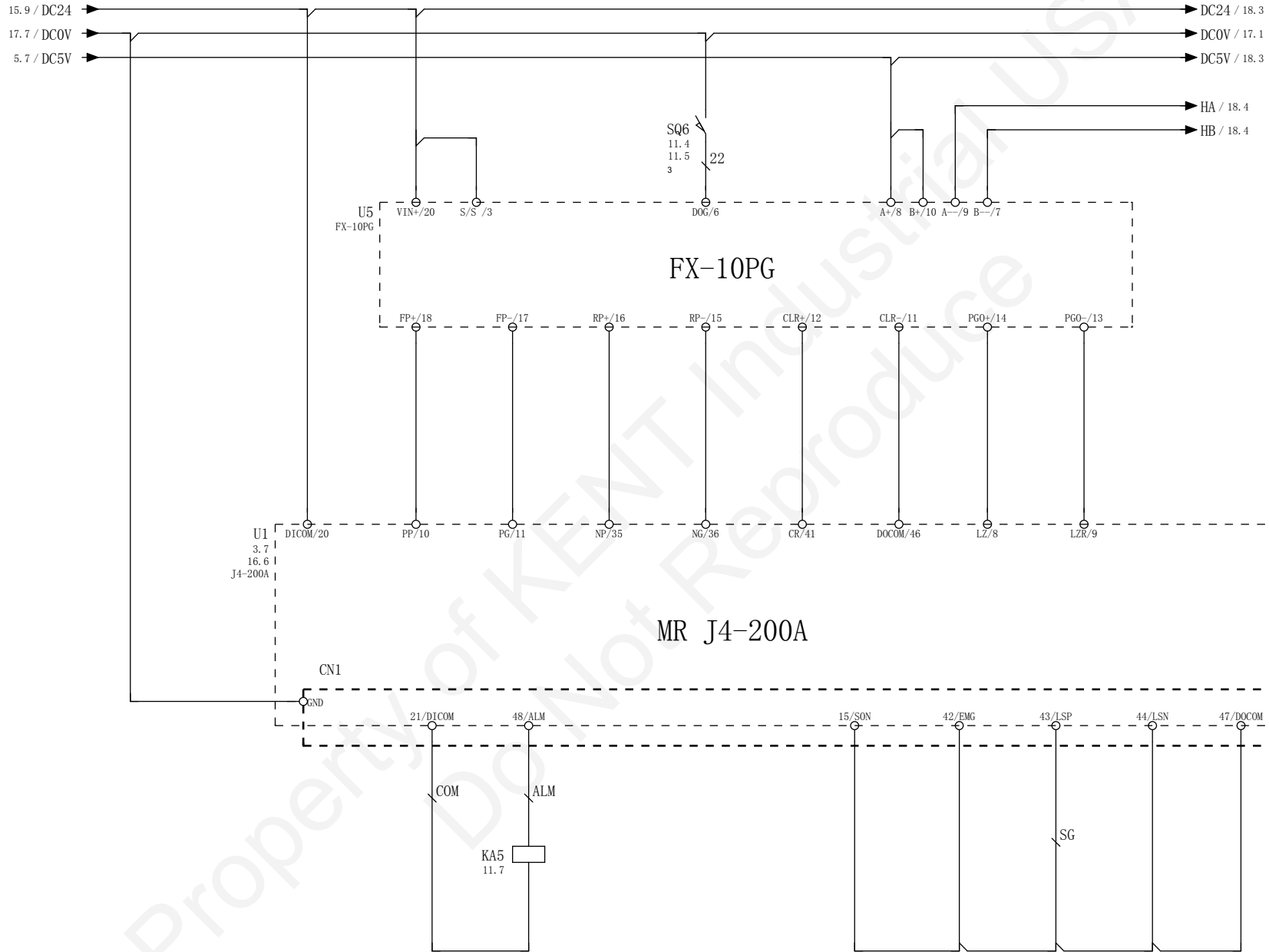

		Date	2023/7/19	V4.0			CONTECTION CIRCUIT			
		Ed.	8143							
		Appr								
Modification	Date	Name	Original	Replacement of	Replaced by			KUG-NC1 (J4 CE)	Page	17
									Page	17 / 22

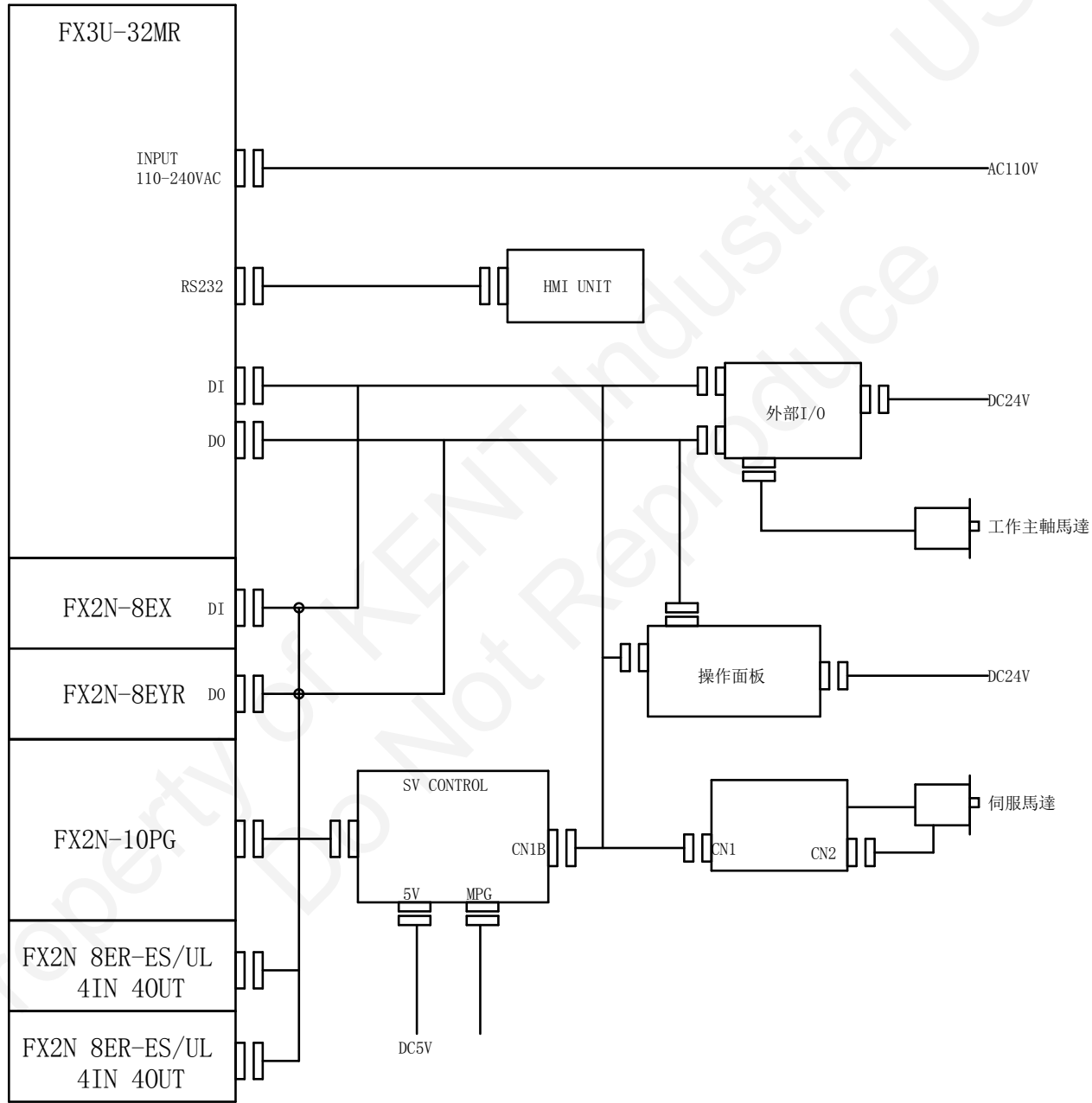

Date		2020/4/9		V4.0		CONNECTION CIRCUIT		=	
Ed.		8143						+	
Appr									
Modification	Date	Name	Original	Replacement of	Replaced by			KUG-NC1 (J4 CE)	Page 19
									Page 19/22

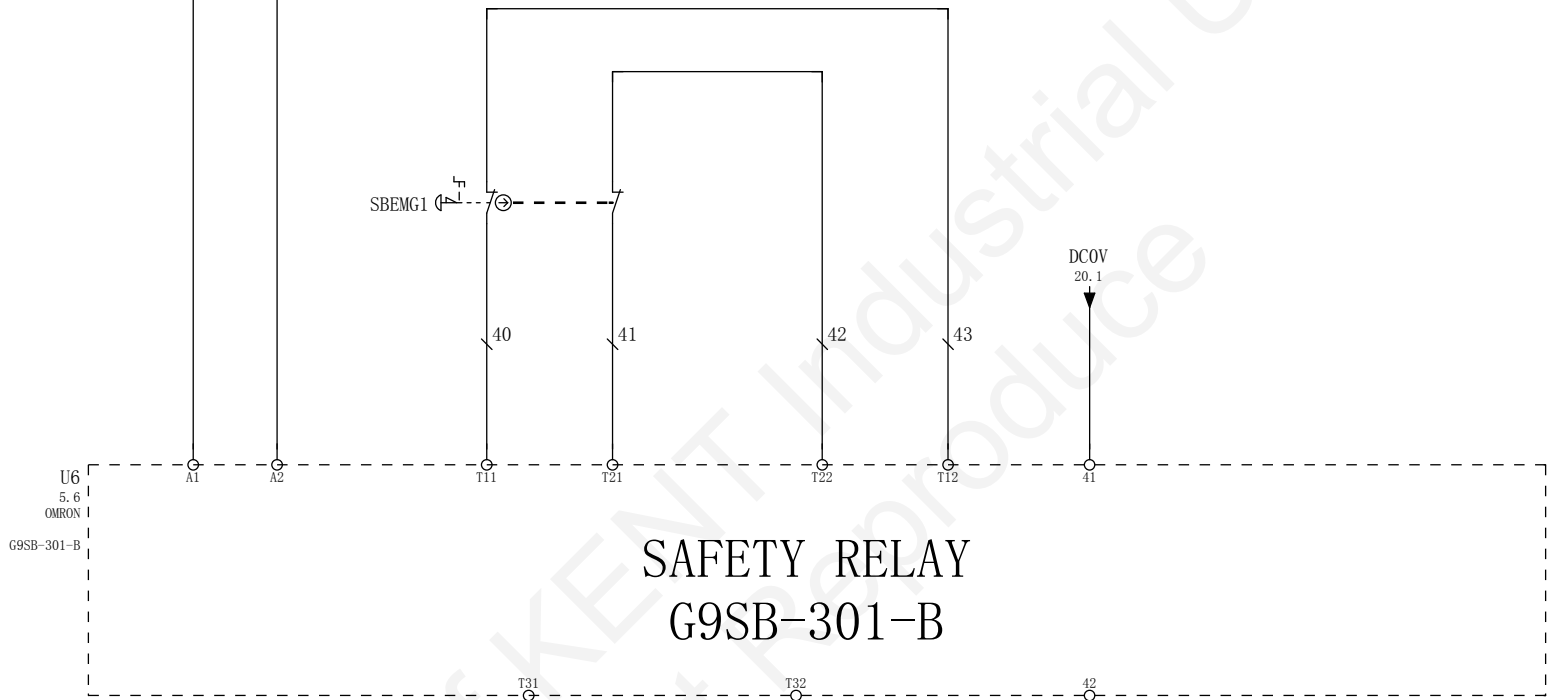
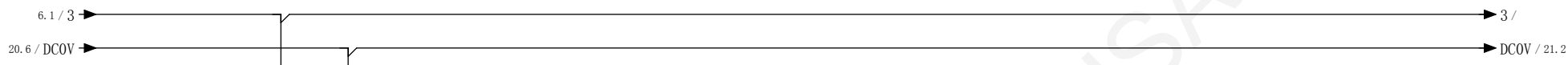

SAFETY RELAY
G9SB-301-B

[T11-T12 ON] + [T21-T22 ON]
 ↓
 [T31-T32 ON]
 ↓
 [13-14 ON] + [23-24 ON]
 [33-34 ON] + [41-42 OFF]

Safety ready singl
SB11

		Date	2023/7/19	V4.0		SAFETY MODULE		=	
		Ed.	8143					+	
		Appr							
Modification	Date	Name	Original	Replacement of	Replaced by	KUG-NC1 (J4 CE)		Page	20
								Page	20 / 22

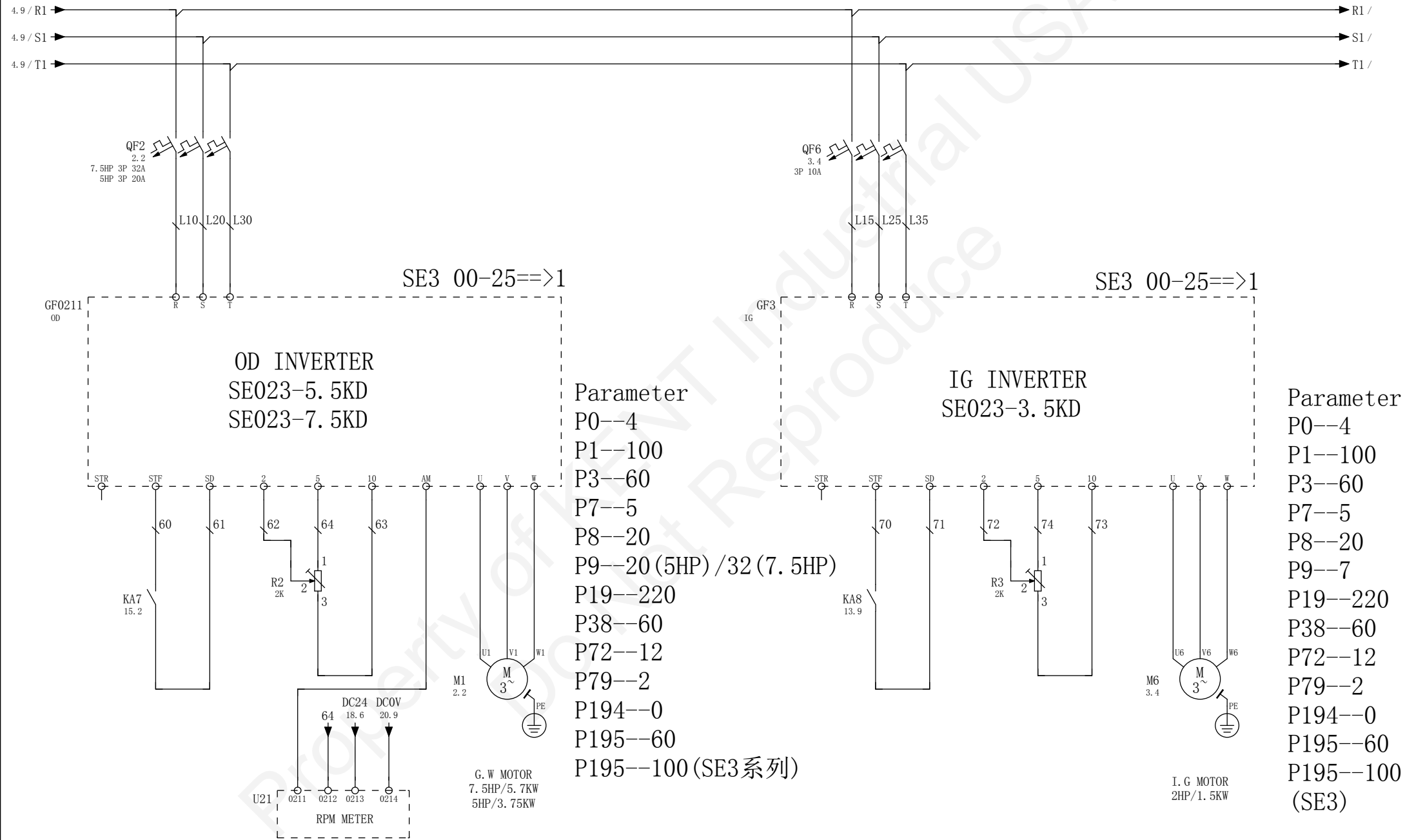

- Parameter
- P0--4
 - P1--100
 - P3--60
 - P7--5
 - P8--20
 - P9--20 (5HP) / 32 (7.5HP)
 - P19--220
 - P38--60
 - P72--12
 - P79--2
 - P194--0
 - P195--60
 - P195--100 (SE3系列)

- Parameter
- P0--4
 - P1--100
 - P3--60
 - P7--5
 - P8--20
 - P9--7
 - P19--220
 - P38--60
 - P72--12
 - P79--2
 - P194--0
 - P195--60
 - P195--100 (SE3)

Date	2023/7/19	V4.0							
Ed.	8143								
Appr									
Modification	Date	Name	Original	Replacement of	Replaced by				

