

RADIAL ARM DRILL

TRD-SERIES

www.kentusa.com

Clamping Systems

Manual Clamping

TRD-720A•TRD-820A•TRD-920A•TRD-1100

In-built mechanical Forward/Reverse switch functions for longer service life with low maintenance.

The Arm Slider is made of high-class cast-iron and processed under severe Heat-Treatment.

A 2HP motor provides various speed selections during heavy-duty cutting.

The main spindle is balanced by a specially designed spring that is more durable than any other traditional balance mechanisms.

The over-load protective devices can secure the operator against injury.

Extra auxiliary dial for Spindle Feed Depth Indication. With this indicator we can review the momental feed depth of the spindle from 0.03" through 8" at any moment.

(for TRD-720A, TRD-820A, TRD-920A)



Hydraulic Clamping

TRD-1230H

12 spindle speed and 3 feed rates

Centralized single level control for forward and reversal of spindle

Ultra low noise

Light and handy to operate

Safety overload

Auxiliary dial for spindle feed depth

With standard accessories



Clamping Systems

Hydraulic Clamping

TRD-1600H•TRD-2000H•TRD-C2500

The Radial Drill Arm adopts IC Timer with advantage of one bottom press, it can automatically release up/down movement, stop, and automatically clamping easy to operate. The spindle can still maintain in original set after the tools change.

Special arm elevating safety device is provided to prevent arm from falling down abruptly after year of usage . It will keep us from injurious dropping whenever the copper nut is excessively worn.

Exclusively for gears type cycling oil pump is furnished to cool off precise gears inside gear box, and minimize excessive wear on gears to lowest extent. (for TRD-1600H, TRD-2000H, TRD-C2500)

Friction type disc clutch is adopted to absorb impact force caused by vertical movement of spindle, and effectively protect all transmission unit inside gear box. With the function of quick spindle return, this clutch will also help us to speed up our tapping operation. (for TRD-1600H, TRD-2000H, TRD-C2500)

Column, Arm, Gear box can clamp at same time by a push button for all model machines except TRD-1600H and TRD-2000H which use cross switch.

Automatic tool releasing device effectively increases tool changing. (for TRD-1600H, TRD-2000H)

Equipped with hydraulic clamping system, with proper selection on change switch, column, arm, gear box can be clamped/released independently. (for TRD-C2500)

Speed Changing function is driven by hydraulic power and equipped with quick preset device for TRD-C2500.

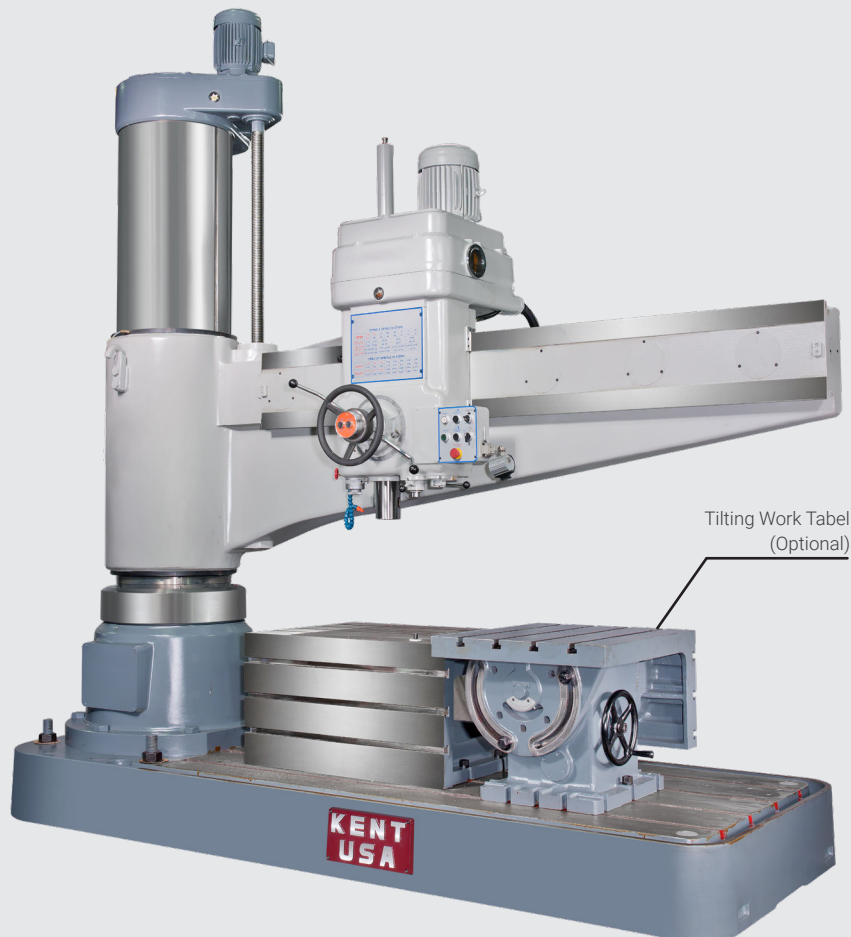

Accessories

Standard Accessories

1. Adjustment Tools (Box Included)
2. Cooling Device (Pump Included)
3. Lighting Device (Fluorescent Lamp Included)
4. Box-Type Work Table

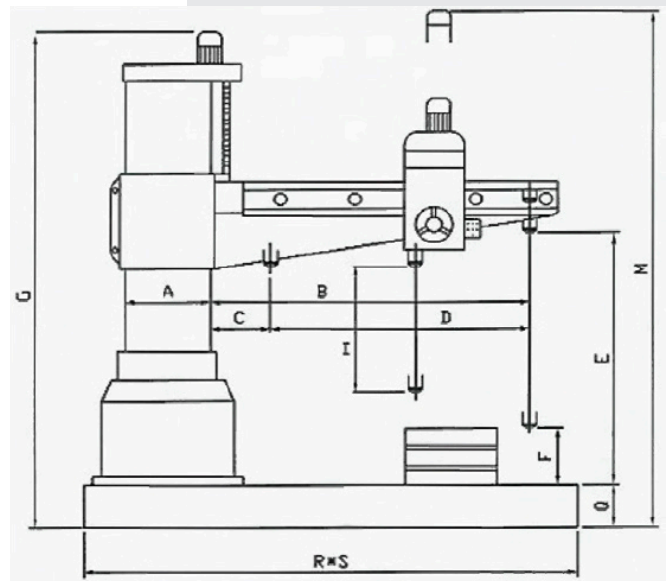

Special Options / Tilt Tables

Uni-tilt table tilts full 90 degrees. Calibrated indicator shows degree of tilt has accurately planed top.

1. DT33 - MT#4 Drill Tapping Set
2. DT33 - MT#5 Drill Tapping Set
3. 5/8 Clamping Kit
4. 3/4 Clamping Kit
5. M18 Clamping Kit

Dimensions (LxWxH)

1. Large Size: 32" x 27" x 24"

Application: TRD-1600H / TRD-2000H / TRD-C2500

2. Small Size: 20" x 20" x 22"

Application: TRD-720A - TRD1600H



Functions

Control Functions



1. P/B Switch for Clamping
2. Lever for Spindle Forward/Reverse
3. P/B switch for Arm Down
4. P/B Switch for Arm Uplift
5. P/B Switch for Release
6. Pole Change Switch
7. Power Indicator
8. Emergency Stop Switch
9. Coolant Water Switch
10. Feed Indicator
11. Coolant Water Adjustment Switch

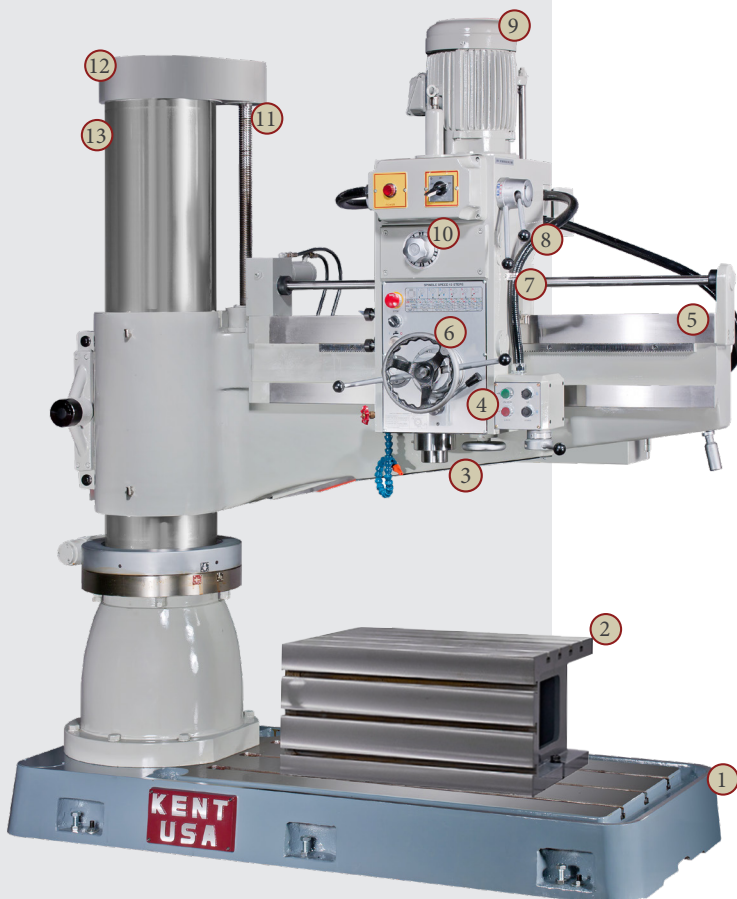

1. Base
2. Box-Type Work Table
3. Spindle
4. Feed Lever
5. Arm
6. Hand-wheel
7. Three Step Speed Change Lever
8. Two Step Speed Change Lever
9. Main Motor
10. Feed Rate Change Switch
11. Lead Screw
12. Top Cover
13. Column

Specifications

Manual/Electric Clamping

Model	TRD-720A	TRD-820A	TRD-920A	TRD-1100
Dai. of Column	8"			10"
Max Distance from Column Surface to Spindle Center	30"	35"	40"	45"
Min Distance from Column Surface to Spindle Center	9"	10"	8"	10"
Travel of Spindle Head	20"	25"	30"	33"
Max Distance from Base Surface to Spindle End	41"	48"	49"	50"
Min Distance from Base Surface to Spindle End	10"	14"	15"	19"
Elevating Height of Arm	23"	25"		22"
Effective Area of Box Table	23" x 17" x 15"			25" x 20" x 16"
Dimension of Base	49" x 25" x 6"			50" x 25" x 6"
Taper Hole Spindle	MT#4			
Stroke of Spindle	8"			9"
Spindle RPM 50 HZ (Rev. x Steps)	73~1247x6			37~1253x12
Spindle RPM 60HZ (Rev. x Steps)	88~1500x6			44~1500x12
Feed of Spindle (Rev. x Steps)	0.002", 0.004", 0.006 x 3			
Main Motor (HP)	2 hp 2 hp			3 hp (Two Speed Motor)
Elevating Motor (HP)	1 hp			
Clamping Motor (HP)	-	-	-	-
Coolant Equipment (HP)	1/8 hp			
Machine Height from Floor (Max)	85"	91"	92"	101"
Base + Column Height	71"	79"	80"	78"
Net Weight	2590 lbs	2645 lbs	2820 lbs	3968 lbs
Shipping Weight	2910 lbs	2976 lbs	3086 lbs	4300 lbs
Shipping Dimensions (LxWxH)	64" x 31" x 85"	66" x 31" x 87"	70" x 31" x 87"	74" x 33" x 87"
Drilling Steel	32			42
Drilling Cast Iron	50			55
Tapping Steel	25			25
Tapping Cast Iron	32			32

The above specifications are for reference only, we reverse the right to alter them without further notice.

Specifications

Hydraulic Clamping

Model	TRD-1230H	TRD-1600HC	TRD-1600H	TRD-2000H	TRD-C2500
Dai. of Column	12"	13"	17"		21"
Max Distance from Column Surface to Spindle Center	48"	65"	61"	81"	98"
Min Distance from Column Surface to Spindle Center	13"	13"	17"		20"
Travel of Spindle Head	24"	52"	44"	64"	78"
Max Distance from Base Surface to Spindle End	53"	55"	64"	76"	79"
Min Distance from Base Surface to Spindle End	18"	18"	15"	16"	22"
Elevating Height of Arm	24"	26"	34"	47"	43"
Effective Area of Box Table	25" x 20" x 16"	25" x 20" x 20"	27" x 20" x 16"	40" x 32" x 20"	
Dimension of Base	68" x 28" x 7"	100" x 38" x 8"	97" x 40" x 8"	114" x 44" x 10"	138" x 55" x 12"
Taper Hole Spindle	MT#4	MT#5			MT#6
Stroke of Spindle	11"		15"		18"
Spindle RPM 50 HZ (Rev. x Steps)	37~1253 x 12	44~1206 x 12	29~157 5x 12		16~1250 x 16
Spindle RPM 60HZ (Rev. x Steps)	44~1500 x 12	56~1450 x 12	35~1890 x 12		16~1250 x 16
Feed of Spindle (Rev. x Steps)	0.002", 0.004", 0.006 x 3	0.002", 0.003", 0.007" x 3	0.003"-0.04" x 6		0.001" - 0.126" x 16
Main Motor (HP)	3hp (Two Step Motor)	5 hp (Two Step Motor)	7 1/2 hp		10 hp
Elevating Motor (HP)	1 hp	2 hp		3 hp	5 hp
Hydraulic Clamping Motor (HP)	1 hp				
Coolant Equipment (HP)	1/8 hp				1/4 hp
Machine Height from Floor (Max)	105"	110"	123"	138"	157"
Base + Column Height	82"	86"	105"	120"	150"
Net Weight	4629 lbs	7275 lbs	9370 lbs	12,345 lbs	24,250 lbs
Shipping Weight	5070 lb	8046 lbs	10,361 lbs	13,448 lbs	27,557 lbs
Shipping Dimensions (LxWxH)	80" x 38" x 88"	106" x 44" x 95"	111" x 58" x 115"	125" x 57" x 130"	163" x 74" x 151"
Drilling Steel	42	50	65		80
Drilling Cast Iron	55	60	70		100
Tapping Steel	2	40	50		65
Tapping Cast Iron	38	50	60		75

The above specifications are for reference only, we reserve the right to alter them without further notice.



Kent Industrial USA, INC
1231 Edinger Avenue
Tustin, CA 92780 USA
Phone: +1.714.258.8526
E-mail: info@kentusa.com
www.kentusa.com